

# NSVT1418L

## Bipolar Transistor -160 V, -1 A, Low $V_{CE(sat)}$ , PNP Single

This device is bipolar junction transistor featuring high current, low saturation voltage, and high speed switching.

Suitable for automotive applications. AEC-Q101 qualified and PPAP capable.

### Features

- Large Current Capacitance
- Low Collector to Emitter Saturation Voltage
- High Speed Switching
- High Allowable Power Dissipation
- AEC-Q101 Qualified and PPAP Capable
- Pb-Free, Halogen Free and RoHS Compliant
- Ultra Small Package Facilitates Miniaturization in End Products

### Typical Applications

- High Side Switch
- Lighting, Infotainment

### ABSOLUTE MAXIMUM RATINGS at $T_A = 25^\circ\text{C}$

Parameter	Symbol	Value	Unit
Collector to Base Voltage	$V_{CBO}$	-180	V
Collector to Emitter Voltage	$V_{CEO}$	-160	V
Emitter to Base Voltage	$V_{EBO}$	-6	V
Collector Current	$I_C$	-1	A
Collector Current (Pulse)	$I_{CP}$	-2	A
Collector Dissipation (Note 1)	$P_C$	0.42	W
Junction Temperature	$T_j$	150	$^\circ\text{C}$
Storage Temperature Range	$T_{stg}$	-55 to +150	$^\circ\text{C}$

Stresses exceeding those listed in the Maximum Ratings table may damage the device. If any of these limits are exceeded, device functionality should not be assumed, damage may occur and reliability may be affected.

1. Surface mounted on ceramic substrate. (250 mm<sup>2</sup> x 0.8 mm)



ON Semiconductor®

[www.onsemi.com](http://www.onsemi.com)



SOT-23  
CASE 318-08

### ELECTRICAL CONNECTION

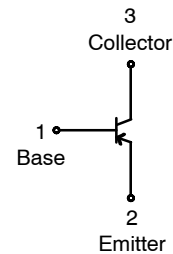

### MARKING DIAGRAM

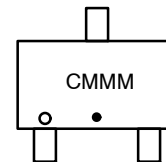

CMM = Specific Device Code  
M = Single Digit Date Code

### ORDERING INFORMATION

See detailed ordering and shipping information on page 5 of this data sheet.

# NSVT1418L

## ELECTRICAL CHARACTERISTICS ( $T_A = 25^\circ\text{C}$ unless otherwise noted)

Parameter	Symbol	Conditions	Value			Unit
			Min	Typ	Max	
Collector Cutoff Current	$I_{CBO}$	$V_{CB} = -120\text{ V}, I_E = 0\text{ A}$			-0.1	$\mu\text{A}$
Emitter Cutoff Current	$I_{EBO}$	$V_{EB} = -4\text{ V}, I_C = 0\text{ A}$			-0.1	$\mu\text{A}$
DC Current Gain	$h_{FE1}$	$V_{CE} = -5\text{ V}, I_C = -100\text{ mA}$	100		400	
	$h_{FE2}$	$V_{CE} = -5\text{ V}, I_C = -10\text{ mA}$	90			
Gain-Bandwidth Product	$f_T$	$V_{CE} = -10\text{ V}, I_C = -50\text{ mA}$		120		MHz
Output Capacitance	$C_{ob}$	$V_{CB} = -10\text{ V}, f = 1\text{ MHz}$		11		pF
Collector to Emitter Saturation Voltage	$V_{CE(sat)1}$	$I_C = -250\text{ mA}, I_B = -25\text{ mA}$		-0.1	-0.5	V
	$V_{CE(sat)2}$	$I_C = -250\text{ mA}, I_B = -50\text{ mA}$		-0.08	-0.13	V
Base to Emitter Saturation Voltage	$V_{BE(sat)}$	$I_C = -250\text{ mA}, I_B = -25\text{ mA}$		-0.8	-1.2	V
Collector to Base Breakdown Voltage	$V_{(BR)CBO}$	$I_C = -10\text{ }\mu\text{A}, I_E = 0\text{ A}$	-180			V
Collector to Emitter Breakdown Voltage	$V_{(BR)CEO}$	$I_C = -1\text{ mA}, R_{BE} = \infty$	-160			V
Emitter to Base Breakdown Voltage	$V_{(BR)EBO}$	$I_E = -10\text{ }\mu\text{A}, I_C = 0\text{ A}$	-6			V
Turn-On Time	$t_{on}$	See Figure 1		90		ns
Storage Time	$t_{stg}$			1000		ns
Fall Time	$t_f$			70		ns

Product parametric performance is indicated in the Electrical Characteristics for the listed test conditions, unless otherwise noted. Product performance may not be indicated by the Electrical Characteristics if operated under different conditions.

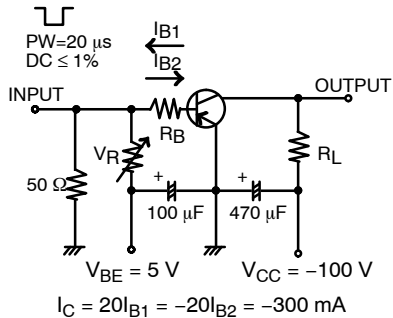

**Figure 1. Switching Time Test Circuit**

TYPICAL CHARACTERISTICS

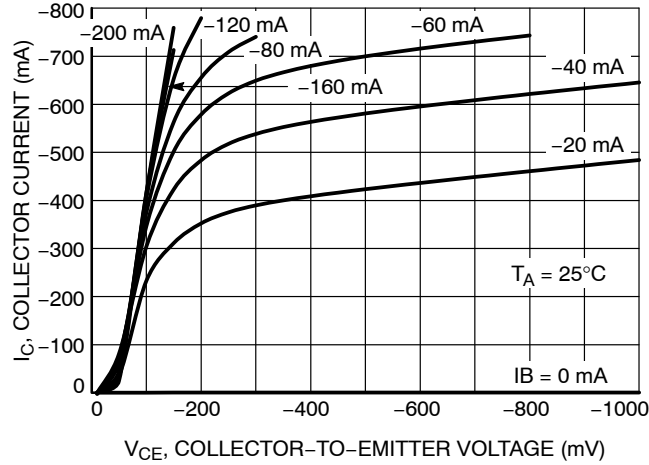

Figure 2.  $I_C$  vs.  $V_{CE}$

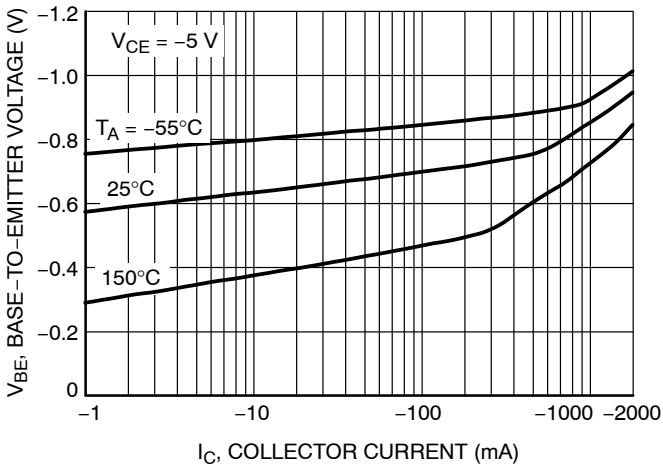

Figure 3.  $V_{BE}$  vs.  $I_C$

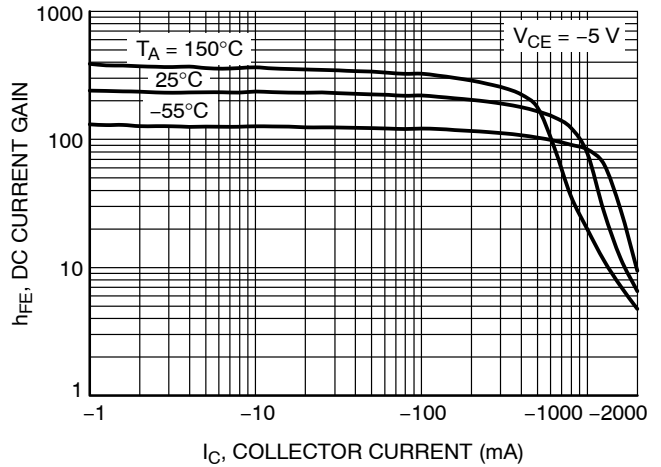

Figure 4.  $h_{FE}$  vs.  $I_C$

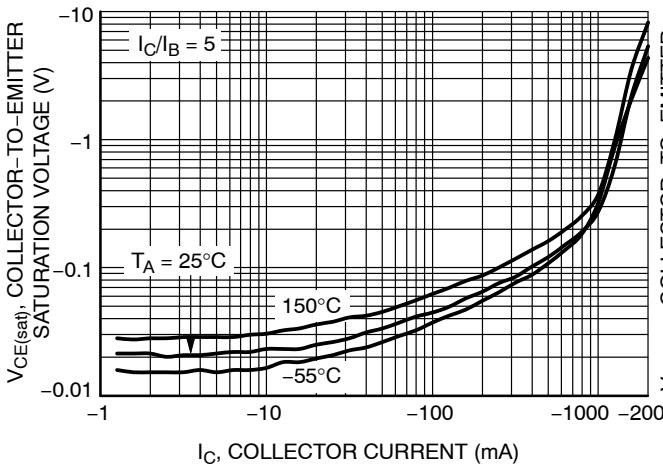

Figure 5.  $V_{CE(sat)}$  vs.  $I_C$

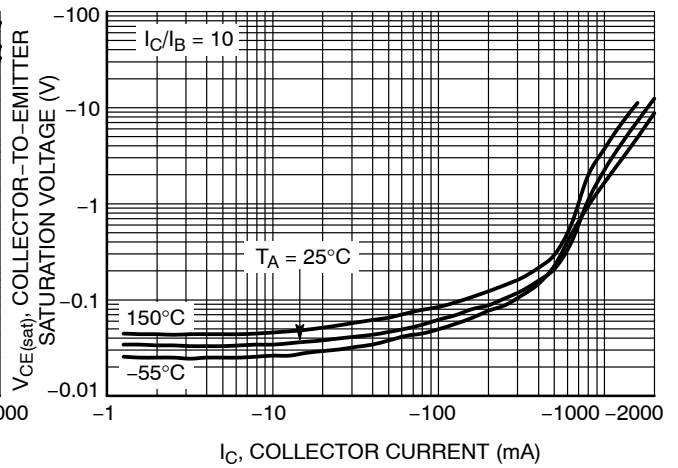

Figure 6.  $V_{CE(sat)}$  vs.  $I_C$

TYPICAL CHARACTERISTICS

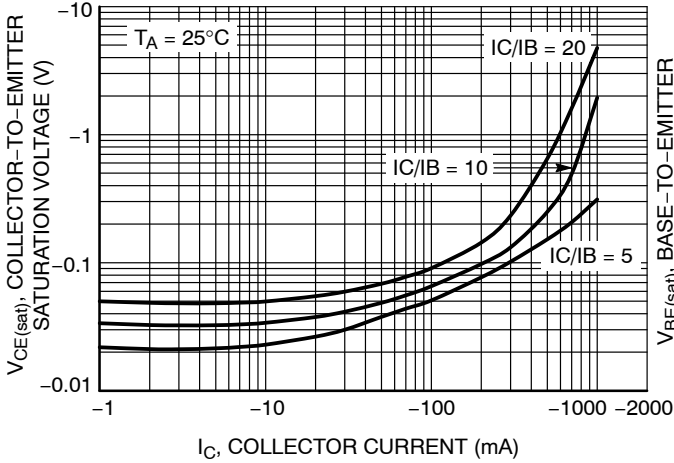

Figure 7.  $V_{CE(sat)}$  vs.  $I_C$

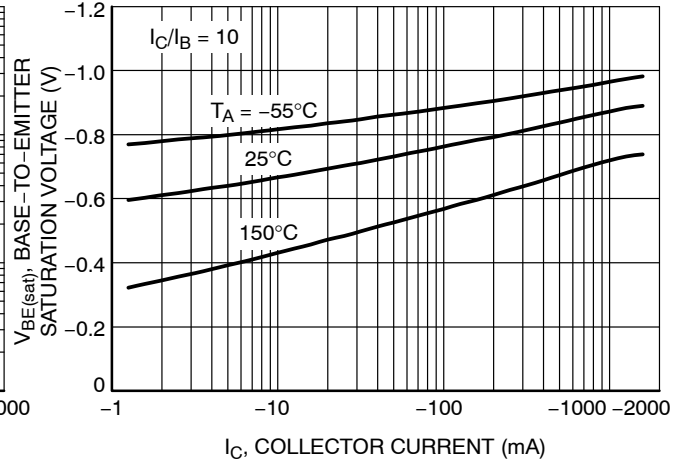

Figure 8.  $V_{BE(sat)}$  vs.  $I_C$

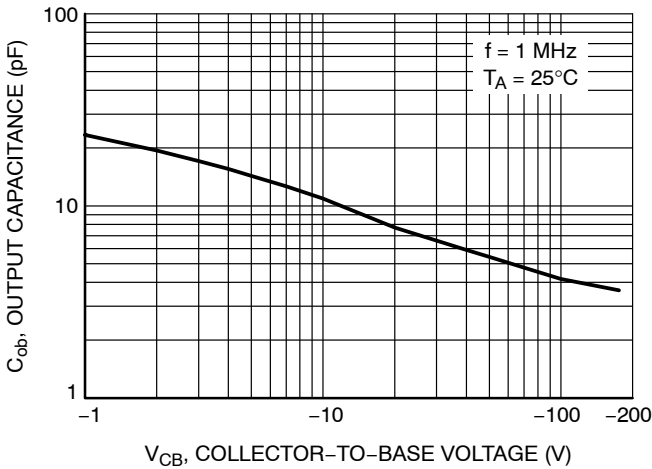

Figure 9.  $C_{ob}$  vs.  $V_{CB}$

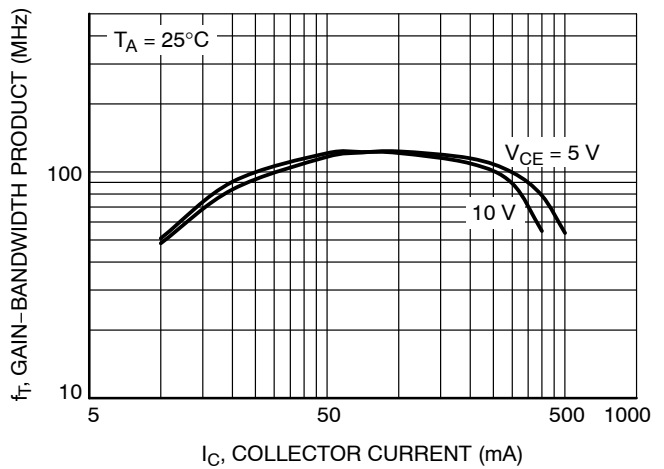

Figure 10.  $f_T$  vs.  $I_C$

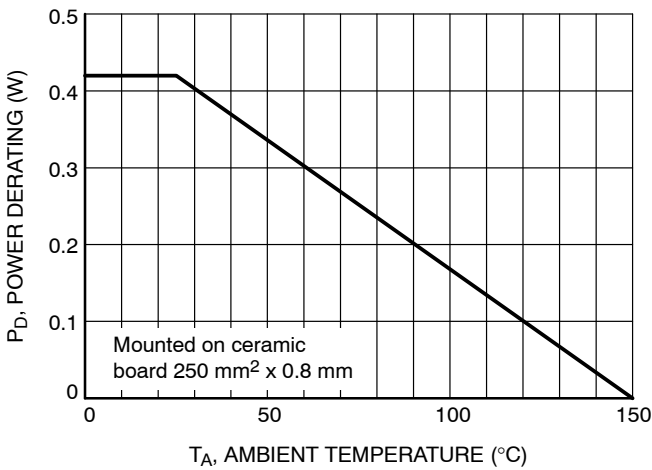

Figure 11. Power Derating

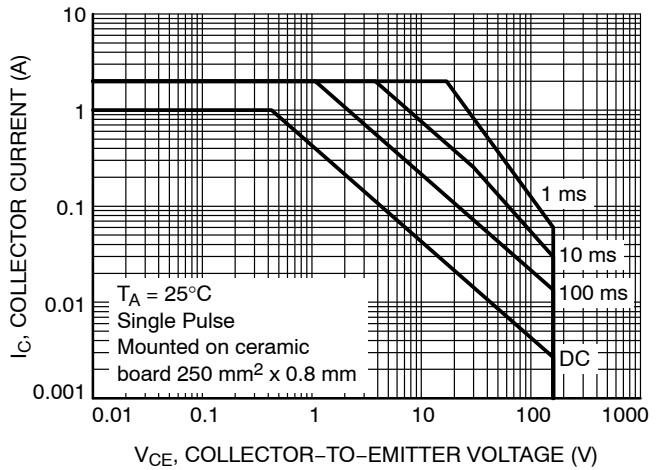

Figure 12. Safe Operating Area

# NSVT1418L

## ORDERING INFORMATION

Device	Marking	Package	Shipping (Qty / Packing) †
NSVT1418LT1G	CMM	SOT-23 (Pb-Free / Halogen Free)	3,000 / Tape & Reel

†For information on tape and reel specifications, including part orientation and tape sizes, please refer to our Tape and Reel Packaging Specification Brochure, BRD8011/D.

## PACKAGE DIMENSIONS

### SOT-23 (TO-236) CASE 318-08 ISSUE AS

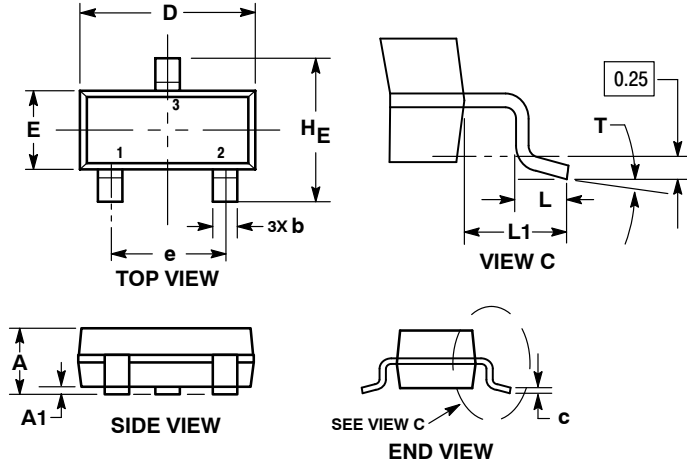

#### NOTES:

1. DIMENSIONING AND TOLERANCING PER ASME Y14.5M, 1994.
2. CONTROLLING DIMENSION: MILLIMETERS.
3. MAXIMUM LEAD THICKNESS INCLUDES LEAD FINISH. MINIMUM LEAD THICKNESS IS THE MINIMUM THICKNESS OF THE BASE MATERIAL.
4. DIMENSIONS D AND E DO NOT INCLUDE MOLD FLASH, PROTRUSIONS, OR GATE BURRS.

DIM	MILLIMETERS			INCHES		
	MIN	NOM	MAX	MIN	NOM	MAX
A	0.89	1.00	1.11	0.035	0.039	0.044
A1	0.01	0.06	0.10	0.000	0.002	0.004
b	0.37	0.44	0.50	0.015	0.017	0.020
c	0.08	0.14	0.20	0.003	0.006	0.008
D	2.80	2.90	3.04	0.110	0.114	0.120
E	1.20	1.30	1.40	0.047	0.051	0.055
e	1.78	1.90	2.04	0.070	0.075	0.080
L	0.30	0.43	0.55	0.012	0.017	0.022
L1	0.35	0.54	0.69	0.014	0.021	0.027
HE	2.10	2.40	2.64	0.083	0.094	0.104
T	0°	---	10°	0°	---	10°

## RECOMMENDED SOLDERING FOOTPRINT

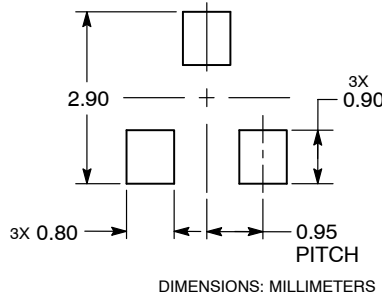

ON Semiconductor and are trademarks of Semiconductor Components Industries, LLC dba ON Semiconductor or its subsidiaries in the United States and/or other countries. ON Semiconductor owns the rights to a number of patents, trademarks, copyrights, trade secrets, and other intellectual property. A listing of ON Semiconductor's product/patent coverage may be accessed at [www.onsemi.com/site/pdf/Patent-Marketing.pdf](http://www.onsemi.com/site/pdf/Patent-Marketing.pdf). ON Semiconductor reserves the right to make changes without further notice to any products herein. ON Semiconductor makes no warranty, representation or guarantee regarding the suitability of its products for any particular purpose, nor does ON Semiconductor assume any liability arising out of the application or use of any product or circuit, and specifically disclaims any and all liability, including without limitation special, consequential or incidental damages. Buyer is responsible for its products and applications using ON Semiconductor products, including compliance with all laws, regulations and safety requirements or standards, regardless of any support or applications information provided by ON Semiconductor. "Typical" parameters which may be provided in ON Semiconductor data sheets and/or specifications can and do vary in different applications and actual performance may vary over time. All operating parameters, including "Typicals" must be validated for each customer application by customer's technical experts. ON Semiconductor does not convey any license under its patent rights nor the rights of others. ON Semiconductor products are not designed, intended, or authorized for use as a critical component in life support systems or any FDA Class 3 medical devices or medical devices with a same or similar classification in a foreign jurisdiction or any devices intended for implantation in the human body. Should Buyer purchase or use ON Semiconductor products for any such unintended or unauthorized application, Buyer shall indemnify and hold ON Semiconductor and its officers, employees, subsidiaries, affiliates, and distributors harmless against all claims, costs, damages, and expenses, and reasonable attorney fees arising out of, directly or indirectly, any claim of personal injury or death associated with such unintended or unauthorized use, even if such claim alleges that ON Semiconductor was negligent regarding the design or manufacture of the part. ON Semiconductor is an Equal Opportunity/Affirmative Action Employer. This literature is subject to all applicable copyright laws and is not for resale in any manner.

## PUBLICATION ORDERING INFORMATION

### LITERATURE FULFILLMENT:

Literature Distribution Center for ON Semiconductor  
19521 E. 32nd Pkwy, Aurora, Colorado 80011 USA  
Phone: 303-675-2175 or 800-344-3860 Toll Free USA/Canada  
Fax: 303-675-2176 or 800-344-3867 Toll Free USA/Canada  
Email: [orderlit@onsemi.com](mailto:orderlit@onsemi.com)

**N. American Technical Support:** 800-282-9855 Toll Free  
USA/Canada  
**Europe, Middle East and Africa Technical Support:**  
Phone: 421 33 790 2910

**ON Semiconductor Website:** [www.onsemi.com](http://www.onsemi.com)

**Order Literature:** <http://www.onsemi.com/orderlit>

For additional information, please contact your local Sales Representative