

# SNAP TEX Cables and Breakout Boards

## Features

- Extend the terminals on your SNAP I/O modules for easier, cleaner wiring to field devices.
- Six-foot (1.8 meter) wiring cables plug into tops of I/O modules for quick replacement.
- Breakout boards offer options such as fusing, power to loads, and mechanical relays.
- Specialty cables integrate older G4 digital I/O with SNAP PAC I/O.

## Description

SNAP TEX cables and breakout boards are part of the SNAP TEX family of wiring and mounting accessories. These parts save time and expense during installation, maintenance, and debugging by reducing the time and effort required to wire field devices to SNAP I/O modules.

Choose the cables and breakout boards for your modules based on the table that starts on [page 2](#).

Specifications, dimensions, and wiring diagrams begin on [page 5](#).

## Part Numbers

Part	Description
<b>Cables</b>	
SNAP-TEX-CBO6	6 ft. (1.8 m), 8-wire cable for SNAP I/O modules. Odd terminals commoned
SNAP-TEX-CBE6	6 ft. (1.8 m), 8-wire cable for SNAP I/O modules. Even terminals commoned
SNAP-TEX-CBS6	6 ft. (1.8 m), 8-wire cable for SNAP I/O modules. Straight-through; no common terminals.
SNAP-HD-ACF6	6 ft. (1.8 m) wiring harness assembly for SNAP 16-point digital modules
SNAP-HD-BF6	6 ft. (1.8 m) wiring harness for 32-channel modules and breakout boards
SNAP-HD-CBF6	6 ft. (1.8 m) wiring harness with flying leads for most 32-point modules
SNAP-HD-G4F6	6 ft. (1.8 m) header cable for SNAP-ODC-32-SNK and SNAP-IDC-32 digital modules and G4PB16H and G4PB16HC mounting racks. Also for SNAP-ODC-32-SRC when connecting to a SNAP-MR10-16C breakout board.
SNAP-HD-G4F6N	6 ft. (1.8 m) header cable for SNAP-IDC-32N digital modules and G4PB16H and G4PB16HC mounting racks



SNAP TEX Family

## SNAP TEX Cables

SNAP TEX cables provide convenient connections from I/O modules to field wiring. Most cables are designed to connect to breakout boards; some cables have flying leads for direct connection to field devices.

## SNAP TEX Breakout Boards

SNAP TEX breakout boards move terminals away from the crowded rack area for easier installation and maintenance. Some breakout boards, such as the SNAP-AIMA-HDB, work only with specific modules; others are designed to be used with several types of modules. See tables starting on [page 2](#).

## Part Numbers (continued)

Part	Description
<b>Breakout Boards</b>	
SNAP-TEX-32	32-point breakout board for SNAP I/O modules
SNAP-TEX-FB16-H	16-point breakout board for SNAP I/O modules, with fuses, fuse-blown indicators, & bussed power (120–240 V)
SNAP-TEX-FB16-L	16-point breakout board for SNAP I/O modules, with fuses, fuse-blown indicators, & bussed power (12–24 V)
SNAP-TEX-MR10-4	Mechanical relay breakout board for a 4-channel SNAP digital output module
SNAP-TEX-MR10-16	Mechanical relay breakout board for one high-density or four 4-channel SNAP digital output modules.
SNAP-TEX-MR10-16C	Mechanical relay breakout board for one high-density or four 4-channel SNAP digital output modules. Header connector connects two boards to one high-density digital module. Optional jumper straps.
SNAP-IDC-HDB SNAP-IDC-HDB-FM*	Fused breakout board for SNAP 32-point digital input modules
SNAP-ODC-HDB SNAP-ODC-HDB-FM*	Fused breakout board for SNAP 32-point digital output modules
SNAP-AIMA-HDB SNAP-AIMA-HDB-FM*	Breakout boards for SNAP-AIMA-32 and SNAP-AIMA-32-FM analog input modules
SNAP-AIV-HDB SNAP-AIV-HDB-FM*	Breakout boards for SNAP-AIV-32 and SNAP-AIV-32-FM analog modules

\* Factory Mutual approved

# SNAP TEX Cables and Breakout Boards

## Module, Breakout Board, and Cable Compatibility Charts

Look in the left column for the module you have. Choose the breakout board in the right columns. Compatible cables are shown in the table cells in the center.

### 4-Channel Digital Modules

Module	Breakout Board		
	SNAP-TEX-32	SNAP-TEX-FB16-H SNAP-TEX-FB16-L	SNAP-TEX-MR10-4 SNAP-TEX-MR10-16 SNAP-TEX-MR10-16C
Digital input modules—4-channel			
SNAP-IAC5 SNAP-IAC5A SNAP-IAC5AFM SNAP-IAC5FM SNAP-IAC5MA SNAP-IDC5 SNAP-IDC5-FAST-A SNAP-IDC5-HT SNAP-IDC5-SW SNAP-IDC5-SW-NC SNAP-IDC5D SNAP-IDC5DFM SNAP-IDC5FAST SNAP-IDC5FM SNAP-IDC5G SNAP-IDC5MA SNAP-IDC5Q	SNAP-TEX-CBE6 SNAP-TEX-CBO6 SNAP-TEX-CBS6	SNAP-TEX-CBO6 SNAP-TEX-CBS6	Not used for inputs
Digital output modules—4-channel			
SNAP-ODC5-I SNAP-ODC5-IFM SNAP-ODC5A-I SNAP-ODC5A-IFM	SNAP-TEX-CBS6 SNAP-TEX-CBO6 SNAP-TEX-CBE6	SNAP-TEX-CBS6 SNAP-TEX-CBO6	SNAP-TEX-CBO6
SNAP-OAC5-I SNAP-OAC5-IFM SNAP-OAC5MA SNAP-ODC5MA	SNAP-TEX-CBS6 SNAP-TEX-CBO6 SNAP-TEX-CBE6	SNAP-TEX-CBS6 SNAP-TEX-CBO6	Not used
SNAP-ODC5SRC	SNAP-TEX-CBS6 SNAP-TEX-CBO6	SNAP-TEX-CBS6 SNAP-TEX-CBO6	SNAP-TEX-CBO6 SNAP-TEX-CBS6
SNAP-OAC5 SNAP-OAC5FM SNAP-ODC5ASNK SNAP-ODC5R SNAP-ODC5R5 SNAP-ODC5R5FM SNAP-ODC5RFM SNAP-ODC5SNK SNAP-ODC5SNKFM SNAP-ODC5SRCFM	SNAP-TEX-CBS6 SNAP-TEX-CBO6	SNAP-TEX-CBS6 SNAP-TEX-CBO6	Not used
SNAP-OMR6-A SNAP-OMR6-C			

# SNAP TEX Cables and Breakout Boards

## Module, Breakout Board, and Cable Compatibility Charts (continued)

Look in the left column for the module you have. Choose the breakout board in the right columns. Compatible cables are shown in the table cells in the center.

### 1-, 2-, and 4-Channel Analog Modules

Module		Breakout Board		
		SNAP-TEX-32	SNAP-TEX-FB16-H SNAP-TEX-FB16-L	SNAP-TEX-MR10-4 SNAP-TEX-MR10-16 SNAP-TEX-MR10-16C
Analog input modules (not thermocouples)				
SNAP-AIMV2-4 SNAP-AIV-4 SNAP-AIR40K-4	SNAP-AIMA-4 SNAP-AIMV-4	SNAP-TEX-CBS6 SNAP-TEX-CBE6	Not used for analog modules	
SNAP-AIMA SNAP-AIV-72 SNAP-AIVRMS SNAP-AIV SNAP-AIARMS SNAP-AICTD SNAP-AIRATE SNAP-AIRTD SNAP-AIRTD-10 SNAP-AIRTD-1K SNAP-AICTD-4	SNAP-AIMA-i SNAP-AIMA2-i SNAP-AIV-i SNAP-AIV2-i SNAP-AIARMS-i SNAP-AIARMS-i-FM SNAP-AIVRMS-i SNAP-AIVRMS-i-FM SNAP-AIPM SNAP-AIPM-3V	SNAP-TEX-CBS6	Not used for analog modules	
SNAP-AILC SNAP-AILC-2 SNAP-pH/ORP SNAP-AIMA-iSRC SNAP-AIMA-iSRC-FM SNAP-AIPM-3*	SNAP-AITM-i ** SNAP-AITM2-i ** SNAP-AITM-4i ** SNAP-AITM ** SNAP-AITM-2 **	No cable available	Not used for analog modules	
Analog output modules				
SNAP-AOA-23 SNAP-AOA-28 SNAP-AOA-3 SNAP-AOV-25	SNAP-AOV-27 SNAP-AOV-5 SNAP-AOA-23-iSRC SNAP-AOA-23-iSRC-FM	SNAP-TEX-CBS6	Not used for analog modules	
SNAP-AOD-29		SNAP-TEX-CBS6 SNAP-TEX-CBE6	Not used for analog modules	

\* Not recommended for use with breakout boards due to CT safety concerns.

\*\* Do not use breakout boards with thermocouples.

### High-Density Digital Modules

Module	Breakout Board					Without a breakout board
	SNAP-TEX-32	SNAP-TEX-FB16-H SNAP-TEX-FB16-L	SNAP-TEX-MR10-4 SNAP-TEX-MR10-16 SNAP-TEX-MR10-16C	SNAP-IDC-HDB SNAP-IDC-HDB-FM	SNAP-ODC-HDB SNAP-ODC-HDB-FM	
SNAP-IAC-16 SNAP-IAC-A-16 SNAP-IAC-K-16 SNAP-IDC-16 SNAP-IDC-HT-16	SNAP-HD-ACF6 (2 modules/board)	SNAP-HD-ACF6				SNAP-HD-ACF6

## SNAP TEX Cables and Breakout Boards

Module	Breakout Board					Without a breakout board
	SNAP-TEX-32	SNAP-TEX-FB16-H SNAP-TEX-FB16-L	SNAP-TEX-MR10-4 SNAP-TEX-MR10-16 SNAP-TEX-MR10-16C	SNAP-IDC-HDB SNAP-IDC-HDB-FM	SNAP-ODC-HDB SNAP-ODC-HDB-FM	
SNAP-IDC-32 SNAP-IDC-32-FM SNAP-IDC-32N SNAP-IDC-32D SNAP-IDC-32DN	SNAP-HD-CBF6	SNAP-HD-CBF6 (2 boards/module)		SNAP-HD-BF6		SNAP-HD-CBF6
SNAP-ODC-32-SNK SNAP-ODC-32-SNK-FM	SNAP-HD-CBF6	SNAP-HD-CBF6 (2 boards/module)	Do not use		SNAP-HD-BF6	SNAP-HD-CBF6
SNAP-ODC-32-SRC SNAP-ODC-32-SRC-FM			SNAP-HD-CBF6 SNAP-HD-G4F6 (MR10-16C only)			

### Analog Modules with More Than 4 Points

Module	Breakout Board							Without a breakout board
	SNAP-TEX-32	SNAP-TEX-FB16-H SNAP-TEX-FB16-L	SNAP-TEX-MR10-4 SNAP-TEX-MR10-16 SNAP-TEX-MR10-16C	SNAP-IDC-HDB SNAP-IDC-HDB-FM	SNAP-ODC-HDB SNAP-ODC-HDB-FM	SNAP-AIMA-HDB SNAP-AIMA-HDB-FM	SNAP-AIV-HDB SNAP-AIV-HDB-FM	
SNAP-AITM-8 SNAP-AITM-8-FM SNAP-AIV-8 SNAP-AIMA-8 SNAP-AICTD-8	Can be used; no cable currently available	Not used with analog modules						
SNAP-AIV-32 SNAP-AIV-32-FM	SNAP-HD-CBF6	Not used with analog modules				SNAP-HD-BF6	SNAP-HD-CBF6	
SNAP-AIMA-32 SNAP-AIMA-32-FM	Not recommended			SNAP-HD-BF6			Not recommended	

# SNAP TEX Cables and Breakout Boards

## SNAP-TEX-CBO6, SNAP-TEX-CBE6, SNAP-TEX-CBS6 Cables

These three cables provide neat, protected wiring from the top of the module to the breakout board. Each cable snaps into the top of one module and terminates at the breakout board with 18-gauge, color-coded flying leads, already stripped and ready for wiring. The leads attach easily to the breakout board with spring connectors.

**SNAP-TEX-CBO6**—Odd-numbered terminals are commoned.

**SNAP-TEX-CBE6**—Even-numbered terminals are commoned.

**SNAP-TEX-CBS6**—No common terminals; wiring is straight through.

See the table starting on [page 2](#) to determine the correct cable for your module and breakout board.



This photo shows the contrast between a regularly wired SNAP PAC rack (at upper left) and one using SNAP-TEX-CBE6, -CBO6, and -CBS6 cables (at lower right).

The cables protect top-of-module connections and wires, and make it easier to follow wiring to field devices.

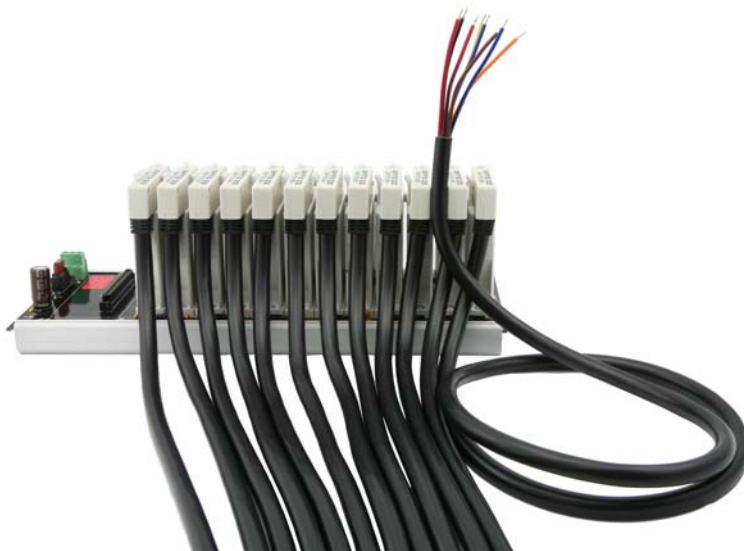

Cables terminate in color-coded flying leads, already stripped and ready for wiring.

Installation, maintenance, and troubleshooting are faster and simpler using the SNAP TEX cables.

# SNAP TEX Cables and Breakout Boards

## SNAP-TEX-CBO6, SNAP-TEX-CBE6, SNAP-TEX-CBS6 Cables (continued)

### Cable Specifications

Feature	SNAP-TEX-CBO6	SNAP-TEX-CBE6	SNAP-TEX-CBS6
Cable length	6 feet (1.8 meters)	6 feet (1.8 meters)	6 feet (1.8 meters)
Connector	8 pins, 0.2 in. (5.08 mm) center-to-center	8 pins, 0.2 in. (5.08 mm) center-to-center	8 pins, 0.2 in. (5.08 mm) center-to-center
Wires	8 pre-stripped, color-coded, 18 gauge	8 pre-stripped, color-coded, 18 gauge	8 pre-stripped, color-coded, 18 gauge
Bussing	Odd-numbered pins connected	Even-numbered pins connected*	No connected
Agency Approvals	CE, RoHS, DFARS	CE, RoHS, DFARS	CE, RoHS, DFARS
Warranty	30 months	30 months	30 months

\*Do NOT USE the CBE6 with a SNAP-TEX-FB16-H or -L breakout board. The FB16s have odd-numbered pins connected.

### Wire Colors

Point	Pin	Color wire
0	1	black
	2	red
1	3	blue
	4	orange

Point	Pin	Color wire
2	5	yellow
	6	brown
3	7	red/black
	8	blue/black



### Compatible SNAP I/O Modules

See table starting on [page 2](#) for detailed module, cable, and breakout board compatibility.

Modules	SNAP-TEX-CBO6	SNAP-TEX-CBE6	SNAP-TEX-CBS6
<b>Use with</b>	SNAP 4-channel digital input and output modules	SNAP 4-channel digital input modules Isolated and -MA digital output modules 4-channel analog modules, except SNAP-AICTD-4 SNAP-AOD-29	SNAP 4-channel digital input and output modules Most 1-, 2-, and 4-channel analog modules
<b>DO NOT use with</b>	Thermocouples Analog modules Modules with more than 4 points	Fused digital output modules Thermocouples Analog modules not listed above Modules with more than 4 points	Thermocouples Modules with more than 4 points SNAP-AITM family, SNAP-pH/ORP, SNAP-AILC family, SNAP-AIMA-iSRC

# SNAP TEX Cables and Breakout Boards

## SNAP-HD-ACF6, SNAP-HD-CBF6, and SNAP-HD-BF6 Cables

The SNAP-HD-ACF6, SNAP-HD-CBF6, and SNAP-HD-BF6 cables connect 16- and 32-channel modules to field wiring or breakout boards. Each cable is 6 ft. (1.8 m) long.

The **SNAP-HD-ACF6** and the **SNAP-HD-CBF6** have connectors at one end that attach to the top of a module and flying leads at the other end for field wiring. The ACF6 is for 16-channel modules and the CBF6 is for 32-channel modules.

The **SNAP-HD-BF6** has connectors at both ends, one for a 32-channel module and the other for a suitable breakout rack.



SNAP-HD-CBF6



SNAP-HD-BF6

### Cable Specifications

See table starting on [page 2](#) for detailed module, cable, and breakout board compatibility.

Feature	SNAP-HD-ACF6	SNAP-HD-CBF6	SNAP-HD-BF6
Cable length	6 feet (1.8 meters)	6 feet (1.8 meters)	6 feet (1.8 meters)
Connectors	Two-connector assembly at module end, each with 16 pins; flying leads at other end	One 40-pin connector at module end; flying leads at other end	One connector at module end; one connector at breakout board end
Wires	Pre-stripped, color-coded, 22-gauge wires	Pre-stripped, color-coded, 24-gauge wires	24 gauge wires
Use with	Modules: SNAP-IAC-16 SNAP-IAC-A-16 SNAP-IAC-K-16 SNAP-IDC-16 SNAP-IDC-HT-16	Modules: SNAP-IDC-32 SNAP-IDC-32-FM SNAP-IDC-32N SNAP-IDC-32D SNAP-IDC-32DN SNAP-ODC-32-SNK SNAP-ODC-32-SNK-FM SNAP-ODC-32-SRC SNAP-ODC-32-SRC-FM SNAP-AIV-32 SNAP-AIV-32-FM	Modules to breakout boards (regular and -FM versions): SNAP-IDC-32 to SNAP-IDC-HDB SNAP-IDC-32N to SNAP-IDC-HDB SNAP-IDC-32D to SNAP-IDC-HDB SNAP-IDC-32DN to SNAP-IDC-HDB SNAP-ODC-32-SNK to SNAP-ODC-HDB SNAP-ODC-32-SRC to SNAP-ODC-HDB SNAP-AIV-32 to SNAP-AIV-HDB SNAP-AIMA-32 to SNAP-AIMA-HDB
Agency Approvals	CE, RoHS, DFARS	CE, RoHS, DFARS	CE, RoHS, DFARS
Warranty	30 months	30 months	30 months

# SNAP TEX Cables and Breakout Boards

## SNAP-HD-ACF6, SNAP-HD-CBF6, and SNAP-HD-BF6 Cables (continued)

### Wiring—From SNAP-HD-ACF6 Cable to SNAP 16-Point Digital Module

The following diagram shows 16-channel module connector wiring for the SNAP-HD-ACF6 wiring harness. Applies to the following modules (top view of module):

- SNAP-IDC-16                      SNAP-IAC-16
- SNAP-IDC-HT-16                SNAP-IAC-A-16
- SNAP-IAC-K-16

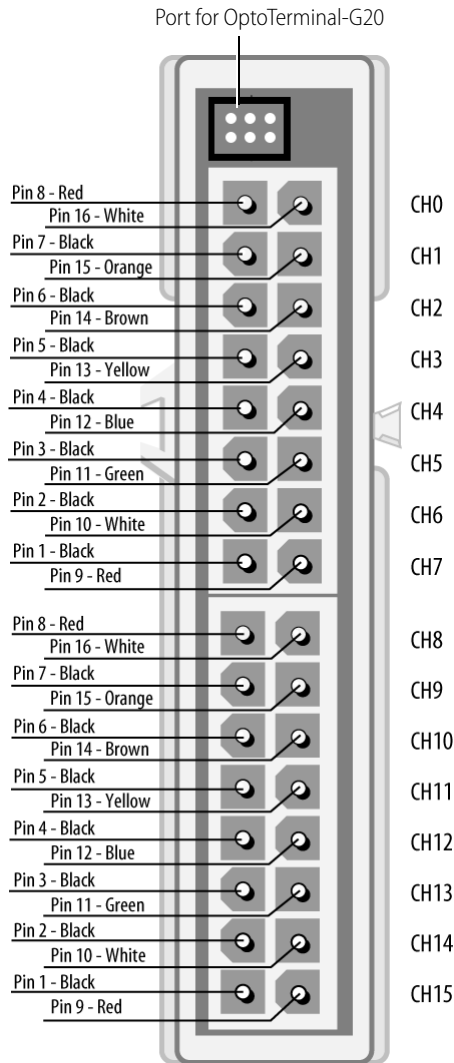



# SNAP TEX Cables and Breakout Boards

## SNAP-HD-ACF6, SNAP-HD-CBF6, and SNAP-HD-BF6 Cables (continued)

### Wiring—SNAP-HD-CBF6 Cable

The following table shows 32-channel module connector wiring for the SNAP-HD-CBF6 wiring harness. Wires from the wiring harness are grouped into four sets. Each set contains color-coded wires.

Set A			Set B			Set C			Set D		
Wires		Point	Wires		Point	Wires		Point	Wires		Point
A0	Gray	0	B0	Gray	8	C0	Gray	16	D0	Gray	24
A1	Blue	1	B1	Blue	9	C1	Blue	17	D1	Blue	25
A2	Yellow	2	B2	Yellow	10	C2	Yellow	18	D2	Yellow	26
A3	Red	3	B3	Red	11	C3	Red	19	D3	Red	27
A4	White	4	B4	White	12	C4	White	20	D4	White	28
A5	Violet	5	B5	Violet	13	C5	Violet	21	D5	Violet	29
A6	Green	6	B6	Green	14	C6	Green	22	D6	Green	30
A7	Orange	7	B7	Orange	15	C7	Orange	23	D7	Orange	31
ACOM	Blk/Brn	com	BCOM	Blk/Brn	com	CCOM	Blk/Brn	com	DCOM	Blk/Brn	com

The four sets relate to point numbers on the module as shown below.

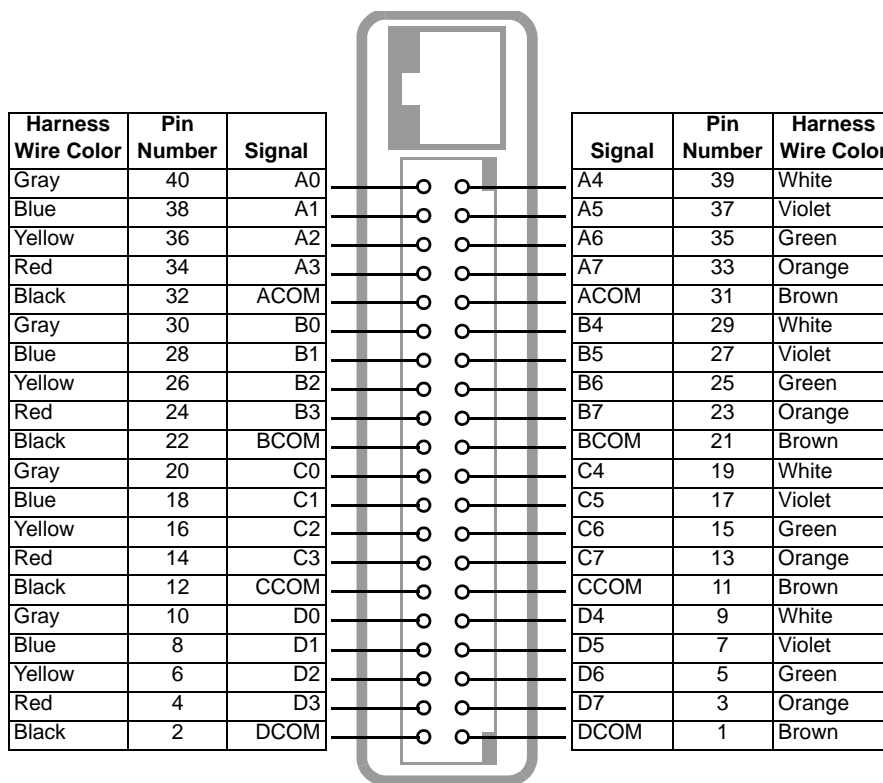

Connector wiring for SNAP-ODC-32-SNK, SNAP-ODC-32-SRC, SNAP-IDC-32, -FM versions, SNAP-IDC-32N, and SNAP-IDC-32DN (top view of module)

# SNAP TEX Cables and Breakout Boards

## SNAP-HD-G4F6 and SNAP-HD-G4F6N Cables

The SNAP-HD-G4F6 and SNAP-HD-G4F6N cables are used to connect a SNAP high-density digital (HDD) module to G4 mounting racks in order to integrate older G4 (or even G1) digital output systems with modern PAC Project software and SNAP PAC Ethernet-based controllers.

For outputs, this connection makes available the G4 output's up to 3-amp switching and sensing capability, which can provide twelve times the 0.25 amp capability of the high-density digital modules themselves. (For details of individual G4 module capabilities, see Opto 22 form #727, the *G4 Digital I/O Data Book*.)

The header cable connects two 16-channel mounting racks to one 32-channel digital module. The cable can also be used to connect G1 mounting racks with header connectors to these modules. See the table below for module and rack compatibility.

The SNAP-HD-G4F6 cable can also be used to connect two SNAP-TEX-MR10-16C breakout boards to one 32-channel digital module. See "[SNAP-TEX-MR10-16C Breakout Board](#)" on page 19.

For more information on HDD modules, see form #1556, the *SNAP High-Density Digital Module Data Sheet*.

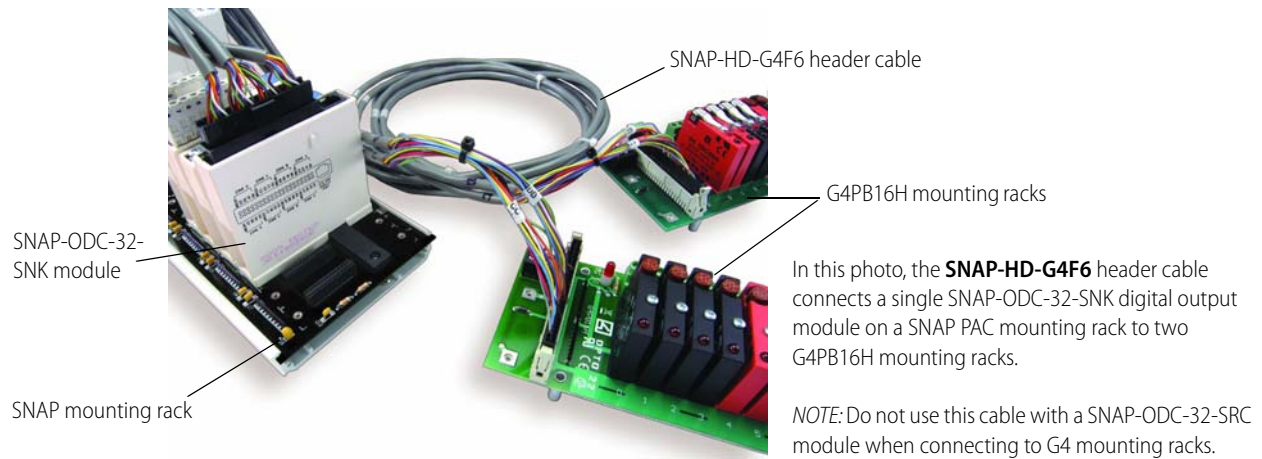

## SNAP-HD-G4F6 and SNAP-HD-G4F6N Cables—Compatible Modules and Racks

Cable	Modules	Racks	Integrated I/O
SNAP-HD-G4F6	SNAP-ODC-32-SNK SNAP-ODC-32-SNK-FM	G4PB16H    PB16H G4PB16HC    PB16HC	G4PB16L    PB16L
SNAP-HD-G4F6N	SNAP-IDC-32N* SNAP-IDC-32DN*	G4PB16H    PB16H G4PB16HC    PB16HC	—

\* For 15 volt or 24 volt G1 or G4 modules, use the SNAP-IDC-32N.  
For 5 volt modules, use the SNAP-IDC-32DN.

*NOTE:* While not designed for this use, it is possible to connect the SNAP-IDC-32 module with G4 15 or 24 V inputs using a SNAP-HD-G4F6 cable. However, the SNAP-IDC-32 uses positive-true logic and therefore returns the inverse of the typical negative-true logic. For example, if the SNAP-IDC-32 is controlled by a PAC Control strategy, an "OFF" state from it actually indicates that the associated G4 module is turned ON.

# SNAP TEX Cables and Breakout Boards

## SNAP-TEX-32, SNAP-TEX-FB16-H, SNAP-TEX-FB16-L Breakout Boards

The **SNAP-TEX-32** is a simple breakout board with straight-through wiring. Designed primarily for 2- and 4-channel analog inputs/outputs and for 4-channel digital inputs, the breakout board is used with SNAP-TEX cables.

The SNAP-TEX-32 can also be used with 8-, 16-, or 32-channel SNAP analog modules (not thermocouples). See the table beginning on [page 2](#) for recommended cable and board combinations for your modules.

The **SNAP-TEX-FB16-H** and **SNAP-TEX-FB16-L** breakout boards provide a fuse and a fuse-blown indicator for each of their 16 channels. In addition, they provide power to loads: the SNAP-TEX-F16-H provides 120–240 volts, and the SNAP-TEX-F16-L provides 12–24 volts. Simply attach the power source to a single spot in the middle of the rack, and power goes out to solenoids or switches, depending on the module

you're using. These breakout boards are used primarily for digital inputs and outputs.

**CAUTION:** Odd pins on the SNAP-TEX-FB16-H and SNAP-TEX-FB16-L breakout boards are commoned. Use *only* straight-through or odd cables with these boards.

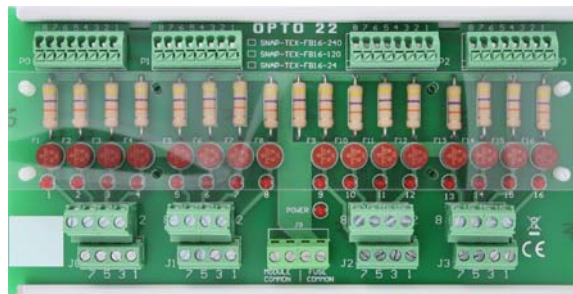

SNAP-TEX-FB16-H

### Specifications

See the table beginning on [page 2](#) for recommended cable and board combinations.

Feature	SNAP-TEX-32	SNAP-TEX-FB16-H	SNAP-TEX-FB16-L
Use with I/O modules	2- or 4-channel analog inputs/outputs; 4-channel digital inputs/outputs *	4-channel digital inputs and outputs 16- and 32-ch digital inputs/outputs	4-channel digital inputs and outputs 16- and 32-ch digital inputs/outputs
Use with cables	SNAP-TEX-CBE6 (even pins connected), SNAP-TEX-CBO6 (odd pins connected), or SNAP-TEX-CBS6 (no connections), depending on module.	<b>4-ch modules:</b> SNAP-TEX-CBO6 (odd pins connected)** or SNAP-TEX-CBS6 (straight-through), depending on module. <b>16-ch modules:</b> SNAP-HD-ACF6 <b>32-ch modules:</b> SNAP-HD-CBF6	<b>4-ch modules:</b> SNAP-TEX-CBO6 (odd pins connected)** or SNAP-TEX-CBS6 (straight-through), depending on module. <b>16-ch modules:</b> SNAP-HD-ACF6 <b>32-ch modules:</b> SNAP-HD-CBF6
Connectors	32 spring connectors; accommodates eight 4-channel modules	16 spring connectors; accommodates four 4-channel modules	16 spring connectors; accommodates four 4-channel modules
Fusing	none	1 A, 250 V, fast-acting fuse for each I/O point (16 total). Replace with Opto 22 PN FUSE01G4	1 A, 250 V, fast-acting fuse for each I/O point (16 total). Replace with Opto 22 PN FUSE01G4
Indicators	none	1 LED per fuse (16 LEDs total)	1 LED per fuse (16 LEDs total)
Bussed power	none	120–240 V	12–24 V
Agency Approvals	CE, RoHS, DFARS	CE, RoHS, DFARS	CE, RoHS, DFARS
Warranty	30 months	30 months	30 months

\* Can also be used with 8-, 16-, or 32-channel digital and analog inputs (not thermocouples).

\*\* **IMPORTANT:** Do NOT USE the FB16 breakout boards with a SNAP-TEX-CBE6 cable. The board has odd pins connected; the cable has even pins connected.

# SNAP TEX Cables and Breakout Boards

## SNAP-TEX-F32, SNAP-TEX-FB16-H, SNAP-TEX-FB16-L (continued)

### Dimensions—SNAP-TEX-32 Breakout Board

Dimensions are shown in inches (with centimeters in parentheses).

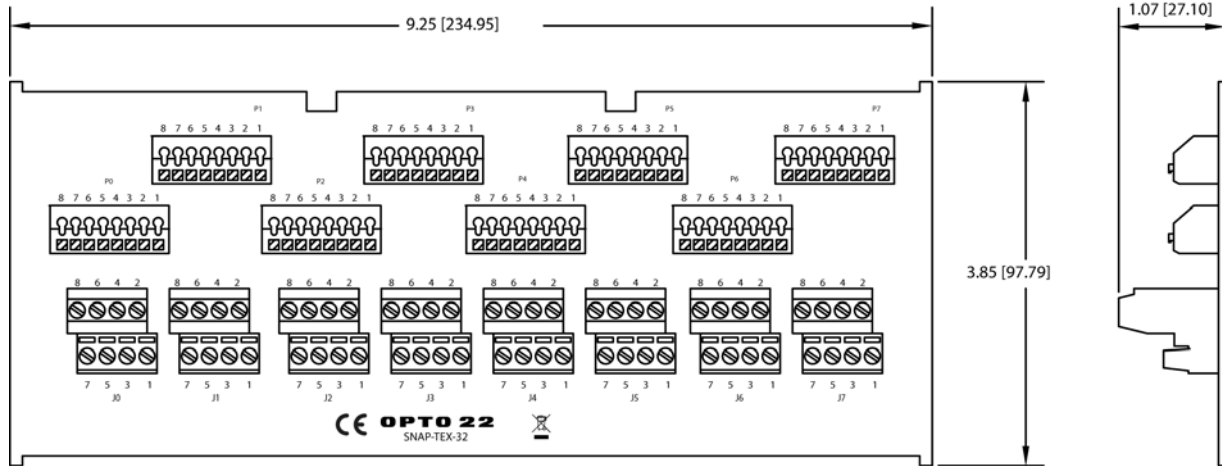

### Dimensions—SNAP-TEX-FB16-H and SNAP-TEX-FB16-L Breakout Boards

Dimensions are shown in inches (with centimeters in parentheses).

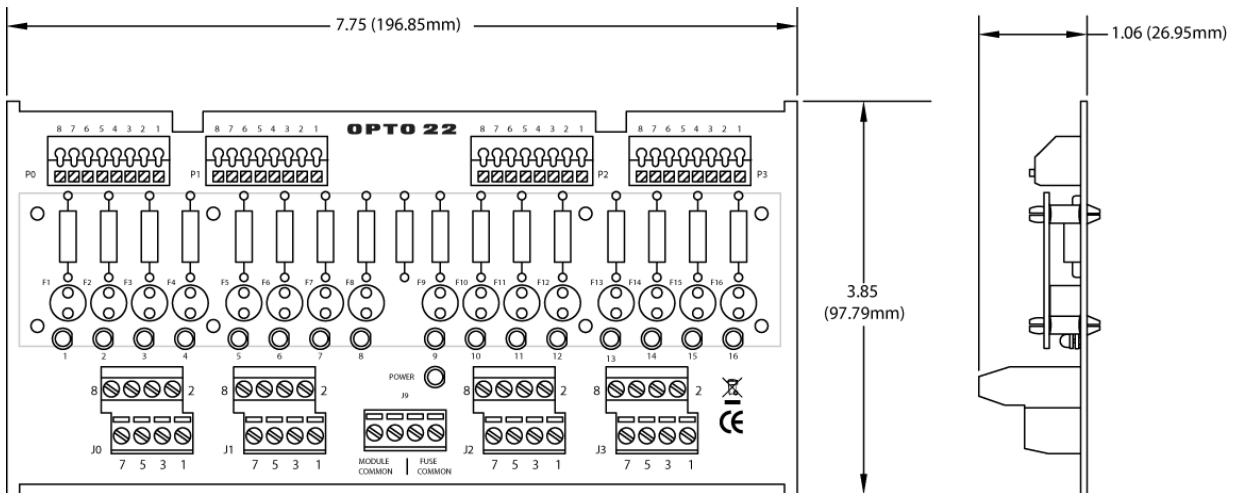

# SNAP TEX Cables and Breakout Boards

## SNAP-TEX-F32, SNAP-TEX-FB16-H, SNAP-TEX-FB16-L (continued)

### Wiring—SNAP-TEX-32 Breakout Board

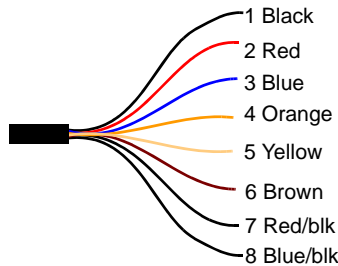

This diagram shows wiring with a SNAP-TEX cable going to a 4-channel module. If you are using the breakout board with other cables going to 16- or 32-channel modules, see the cable's data sheet for wire colors and wiring details.

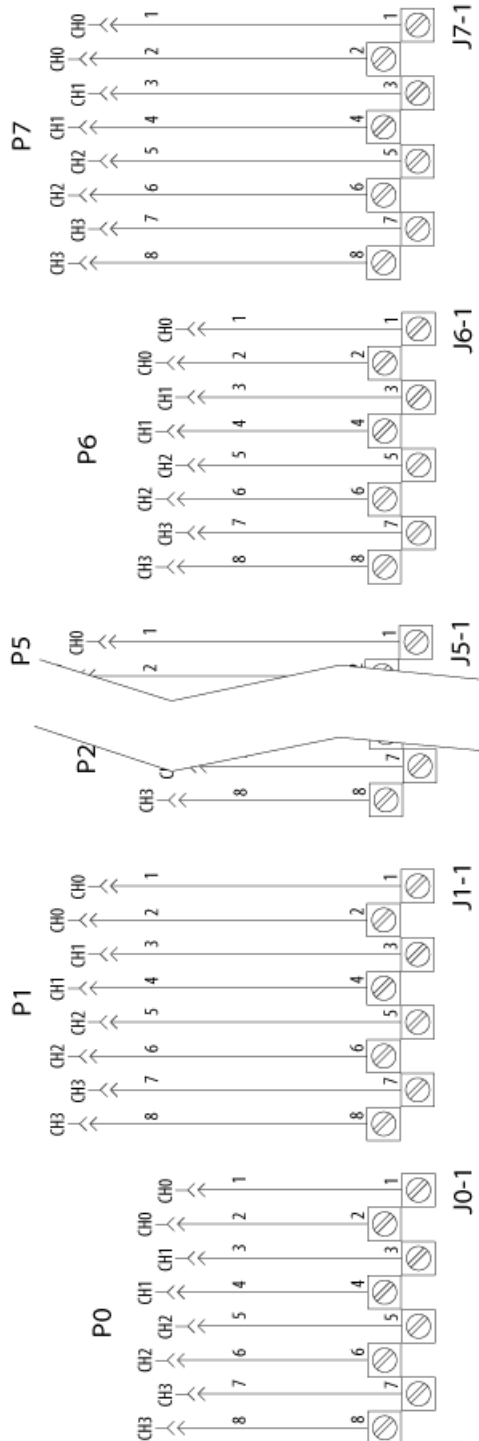

For use with SNAP OACS, OACS-i, ODC-i, ODC5, IAC(s) and IDC(s)  
For use with all 2, 4, 16, 32 CH SNAP analog except thermocouples

# SNAP TEX Cables and Breakout Boards

## SNAP-TEX-F32, SNAP-TEX-FB16-H, SNAP-TEX-FB16-L (continued)

### Wiring—SNAP-TEX-FB16-H and SNAP-TEX-FB16-L Breakout Boards

This diagram shows wiring with SNAP-CBO6 or SNAP-CBS6 cables coming from 4-channel modules. If you are using the breakout board with a SNAP-HD-CBF6 cable coming from 32-channel modules, see [page 15](#).

**CAUTION:** Do NOT use the SNAP-TEX-CBE6 (even pins commoned) cable with this board. The board has odd pins commoned.

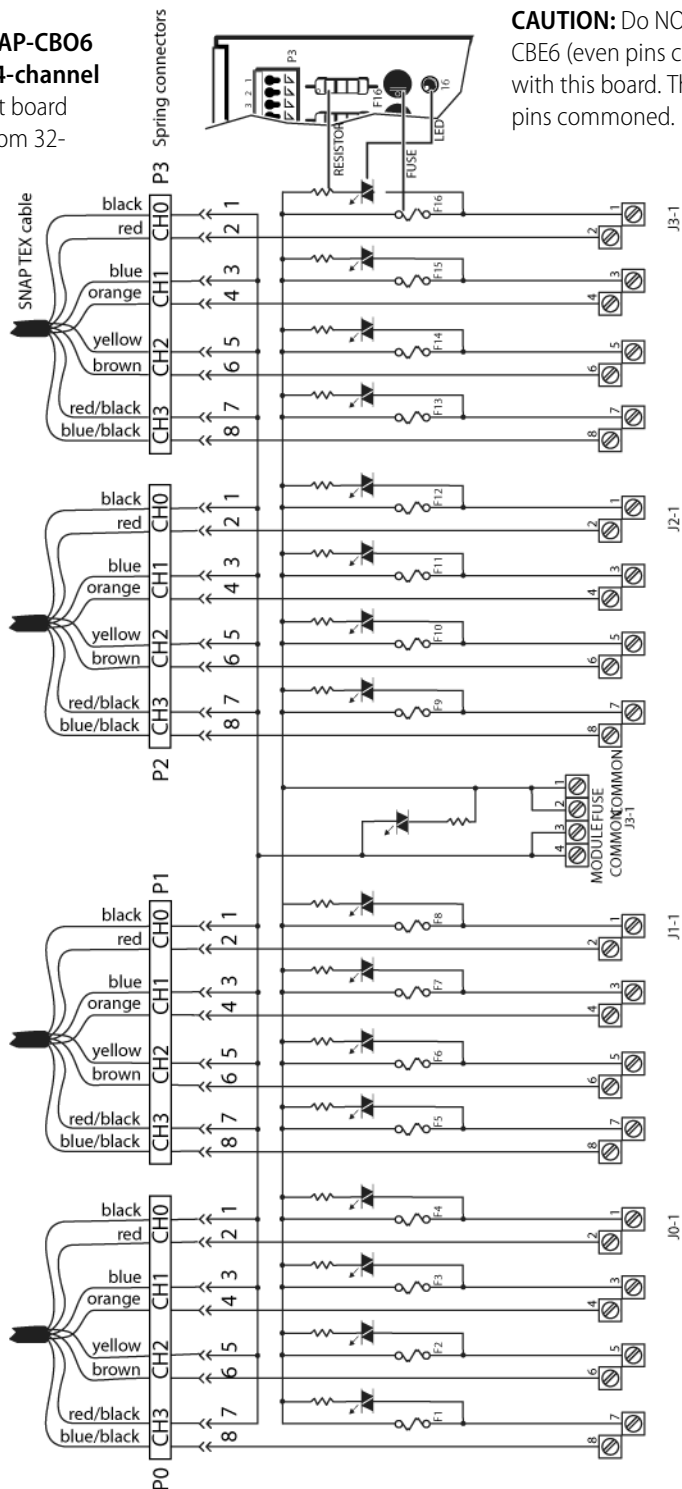

For use with SNAP OAC5, OAC5-i, ODC-i, IAC(s) and IDC(s)  
Use straight-through cable or odd pins bussed

# SNAP TEX Cables and Breakout Boards

## SNAP-TEX-F32, SNAP-TEX-FB16-H, SNAP-TEX-FB16-L (continued)

### Wiring—SNAP-TEX-FB16-L Breakout Board

This diagram shows wiring with a SNAP-HD-CBF6 cable coming from a 32-channel module (SNAP-ODC-32-SRC or SNAP-ODC-32-SNK).

Each module requires two boards.

If you are using the board with 4-channel modules, see the previous page..

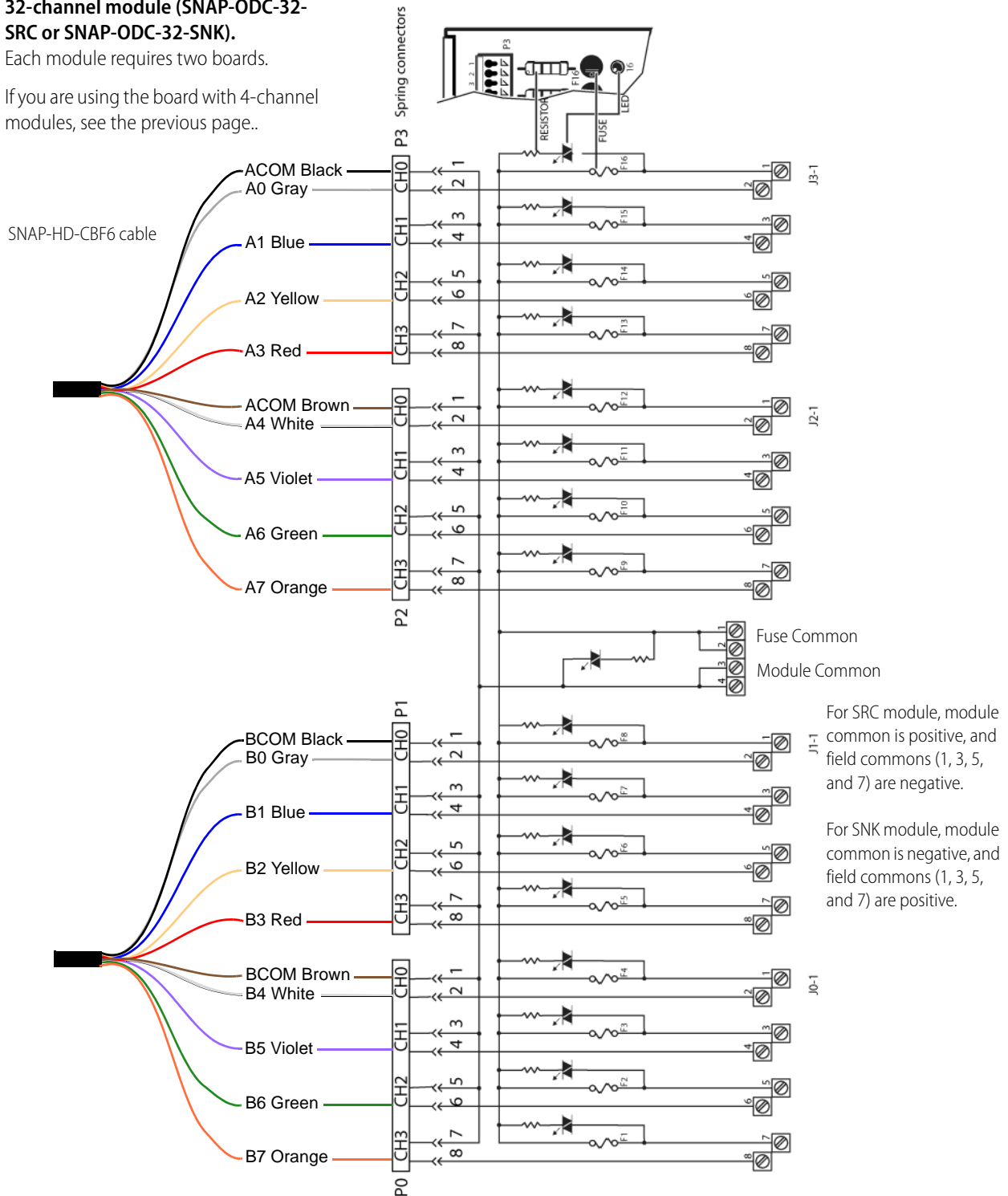

# SNAP TEX Cables and Breakout Boards

## SNAP-TEX-MR10-4 and SNAP-TEX-MR10-16 Breakout Boards

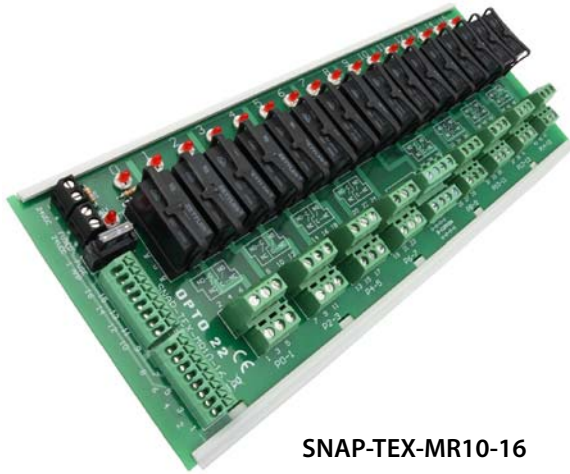

SNAP-TEX-MR10-16

The **SNAP-TEX-MR10-4** and **SNAP-TEX-MR10-16** breakout boards, designed for high-current switching, feature mechanical relays that can switch up to 10 A per channel. (Standard SNAP output modules can switch up to 0.75 A; SNAP-OMR6 output modules can switch up to 6 A.)

These breakout boards include on/off indicators for each channel, and each channel can be wired for normally closed or normally open. The boards require 24 VDC power.

A replacement relay is available, part number SNAP-MR10.

Also see "[SNAP-TEX-MR10-16C Breakout Board](#)" on page 19.

### Specifications

See the tables beginning on [page 2](#) for compatible modules and cables.

Feature	SNAP-TEX-MR10-4	SNAP-TEX-MR10-16
Use with I/O modules	SNAP-ODC5-i, SNAP-ODC5A-i, SNAP-ODC5SRC, SNAP-ODC-32-SRC	SNAP-ODC5-i, SNAP-ODC5A-i, SNAP-ODC5SRC, SNAP-ODC-32-SRC
Use with cables	SNAP-TEX-CBO6 (odd pins bussed), SNAP-TEX-CBS6 (no bussing), or SNAP-HD-CBF6, depending on module.	SNAP-TEX-CBO6 (odd pins bussed), SNAP-TEX-CBS6 (no bussing), or SNAP-HD-CBF6, depending on module.
Relay contacts	SPDT (1 Form C) Typical life expectancy (Electrical): $1 \times 10^5$	SPDT (1 Form C) Typical life expectancy (Electrical): $1 \times 10^5$
Switching capacity	10 A @ 240 VAC	10 A @ 240 VAC
Switch On time	7 ms nominal	7 ms nominal
Switch Off time	3 ms nominal	3 ms nominal
Fusing	24 V fuse for board. Opto 22 p/n SNAP-FUSE1AC	24 V fuse for board. Opto 22 p/n SNAP-FUSE1AC
Indicators	4 On/Off status indicators (one for each channel) 1 fuse-blown indicator	16 On/Off status indicators (one for each channel) 1 fuse-blown indicator
Power requirements (all positions On)	24 VDC @ 75 mA	24 VDC @ 300 mA
Agency Approvals	CE, RoHS, DFARS	CE, RoHS, DFARS
Warranty	30 months from date of manufacture	30 months from date of manufacture



# SNAP TEX Cables and Breakout Boards

## SNAP-TEX-MR10-4 and SNAP-TEX-MR10-16 Breakout Boards (continued)

### Dimensional Drawing—SNAP-TEX-MR10-16 Breakout Board

Dimensions are shown in inches (with centimeters in parentheses).

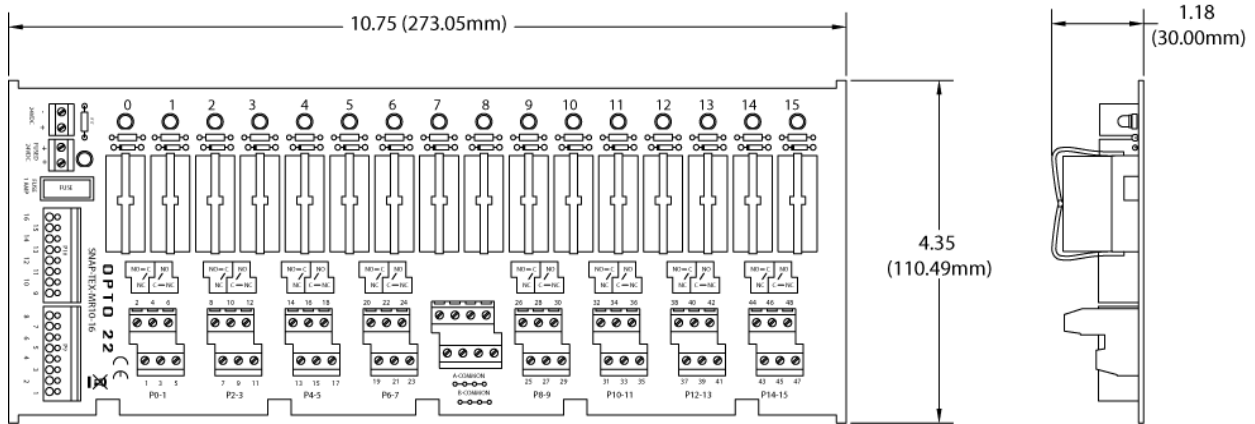

### Dimensional Drawing—SNAP-TEX-MR10-4 Breakout Board

Dimensions are shown in inches (with centimeters in parentheses).

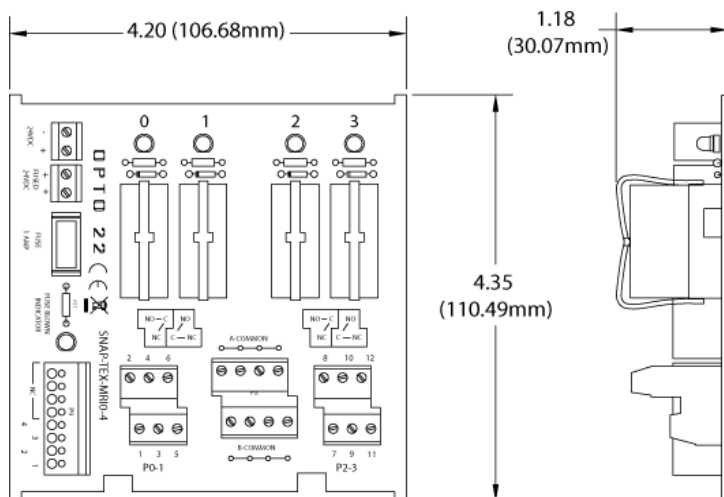

# SNAP TEX Cables and Breakout Boards

## SNAP-TEX-MR10-4 and SNAP-TEX-MR10-16 Breakout Boards (continued)

### Wiring Diagram—SNAP-TEX-MR10-4 Breakout Board

The example below shows wiring from the first two points of a SNAP-ODC5-i output module to a SNAP-TEX-MR10-4 board. Wire colors shown are for a SNAP-TEX-CBO6 cable. Wiring is similar for a SNAP-TEX-MR10-16 board, which has 16 channels rather than four.

This board can also be used with other modules and cables; see the compatibility tables starting on [page 2](#).

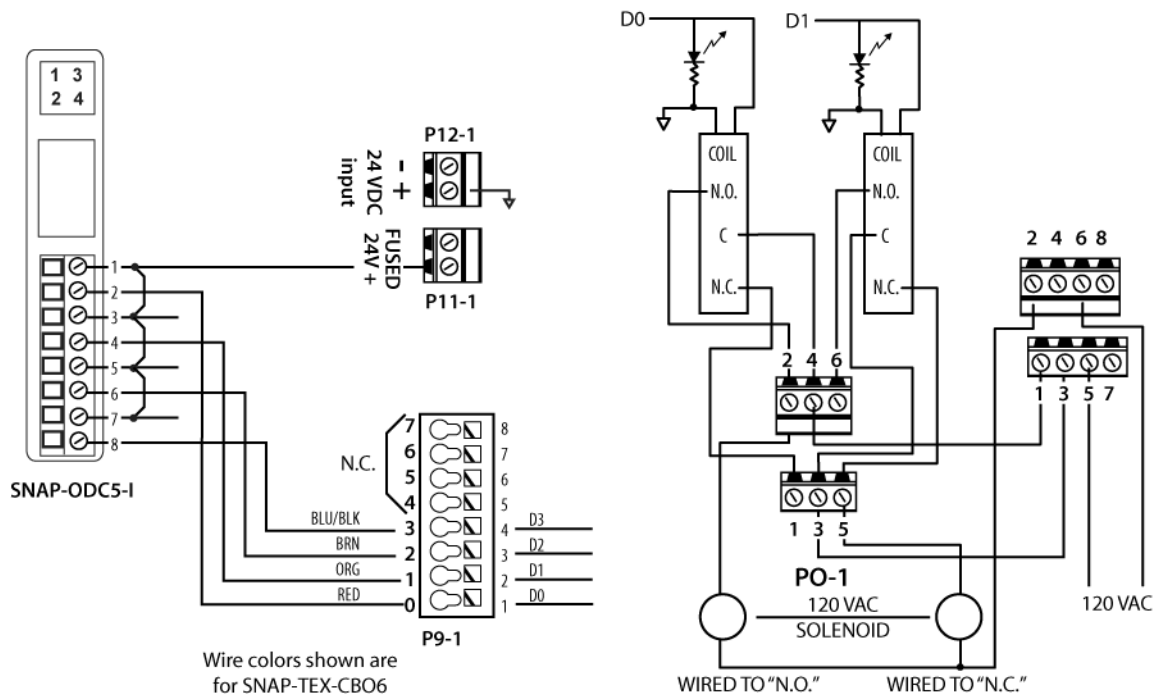

# SNAP TEX Cables and Breakout Boards

## SNAP-TEX-MR10-16C Breakout Board

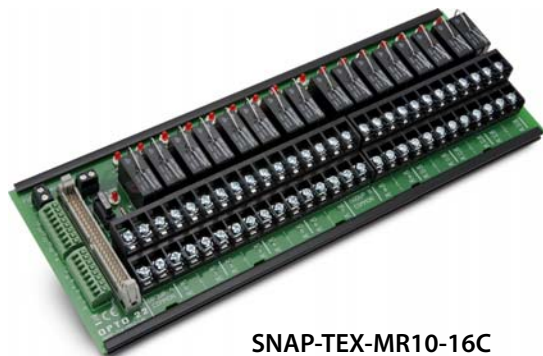

SNAP-TEX-MR10-16C

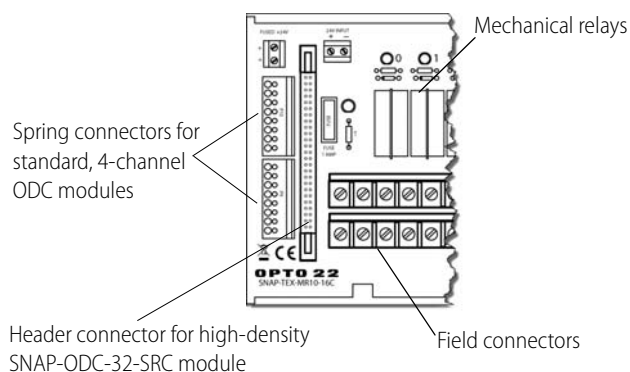

The **SNAP-TEX-MR10-16C** breakout board, designed for high-voltage/high-current switching, features mechanical relays that can switch up to 10 A per channel. (Standard SNAP output modules can switch up to 0.75 A; SNAP-OMR6 output modules can switch up to 6 A.)

This breakout board includes on/off indicators for each channel, and each channel can be wired for normally closed or normally open. The boards require 24 VDC power.

This board allows you to connect digital output modules in two ways:

- Connect 4 standard four-channel ODC modules using the two *spring connectors* and the appropriate cable for the modules. See [page 20](#).
- Connect one SNAP-ODC-32-SRC high-density module to the *header connectors* on two MR10-16C breakout boards. Requires a SNAP-HD-G4F6 cable.

Bussed commons in 2-channel groups provide easier wiring of loads. Bussing straps (STRAP2Q and STRAP4Q) can be used for quick common power connections between relay groups. See [page 21](#).

A replacement relay is available, part number SNAP-MR10.

Also see “[SNAP-TEX-MR10-4 and SNAP-TEX-MR10-16 Breakout Boards](#)” on [page 16](#).

### Specifications

Also see the tables beginning on [page 2](#) for compatible modules and cables.

Feature	SNAP-TEX-MR10-16C
Use with I/O modules	SNAP-ODC5-i, SNAP-ODC5A-i, SNAP-ODC5SRC, SNAP-ODC-32-SRC
Use with cables	<ul style="list-style-type: none"> <li>• For one high-density SNAP-ODC-32-SRC module, use a SNAP-HD-G4F6 cable to connect two breakout boards to one SNAP-ODC-32-SRC module.</li> <li>• For four standard modules, use SNAP-TEX-CBO6 (odd pins bussed), SNAP-TEX-CBS6 (no bussing), or SNAP-HD-CBF6, depending on module.</li> </ul>
Use with jumper straps	STRAP2Q, STRAP4Q
Relay contacts	SPDT (1 Form C) Typical life expectancy (Electrical): 1 x 10 <sup>5</sup>
Switching capacity	10 A @ 250 VAC
Switch On time	7 ms nominal
Switch Off time	3 ms nominal
Fusing	24 V fuse for board. Opto 22 p/n SNAP-FUSE1AC
Indicators	16 On/Off status indicators (one for each channel) 1 fuse-blown indicator
Power requirements (all positions On)	24 VDC @ 300 mA
Agency Approvals	CE, RoHS, DFARS
Warranty	30 months from date of manufacture

# SNAP TEX Cables and Breakout Boards

## SNAP-TEX-MR10-16C Breakout Board (continued)

### Dimensional Drawing—SNAP-TEX-MR10-16C Breakout Board

Dimensions are shown in inches (with centimeters in parentheses).

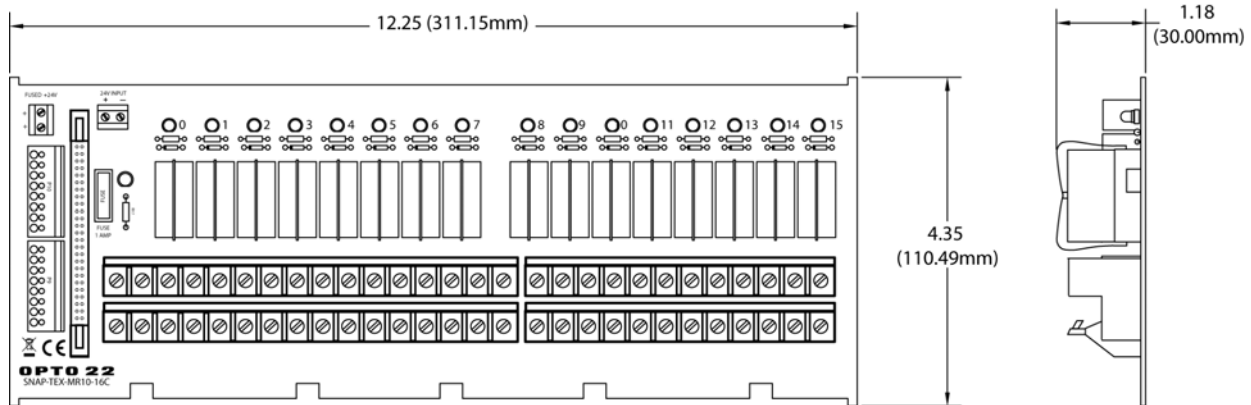

### Wiring Diagram—Connecting Four-Channel ODC Modules to SNAP-TEX-MR10-16C

The example below shows wiring a SNAP-ODC5-i output module to a SNAP-TEX-MR10-16C board. Two four-channel ODC modules can be wired to each of the two spring connectors. Wire colors shown are for a SNAP-TEX-CBO6 cable.

This board can also be used with other modules and cables; see the compatibility tables starting on [page 2](#).

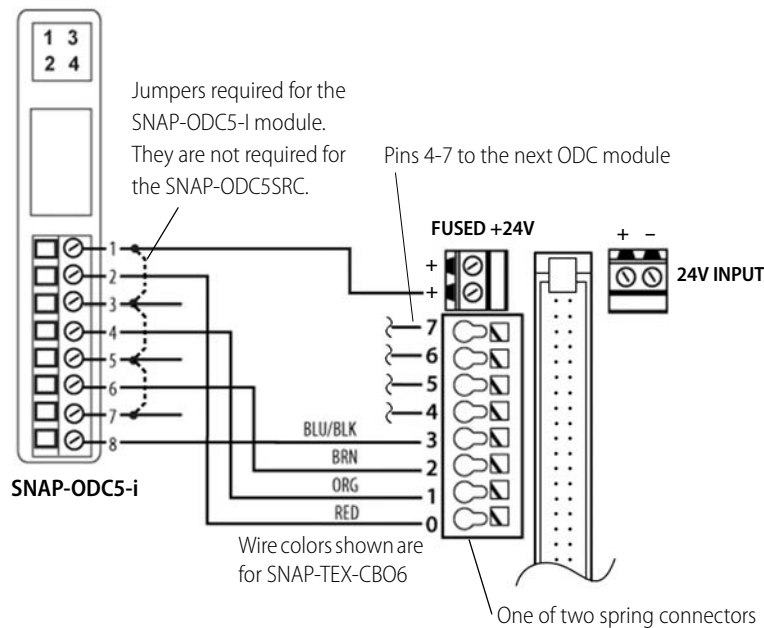

# SNAP TEX Cables and Breakout Boards

## SNAP-TEX-MR10-16C Breakout Board (continued)

### Wiring Diagram—SNAP-TEX-MR10-16C Relay Group

The diagram below shows relays 0 and 1 in a relay group.

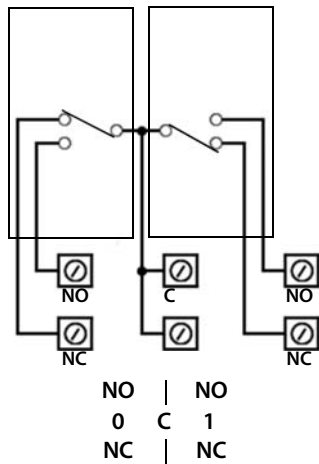

Terminals 0 and 1

### Jumper Straps—SNAP-TEX-MR10-16C Breakout Board

This diagram shows an example using jumper straps, Opto 22 part numbers STRAP2Q and STRAP4Q.

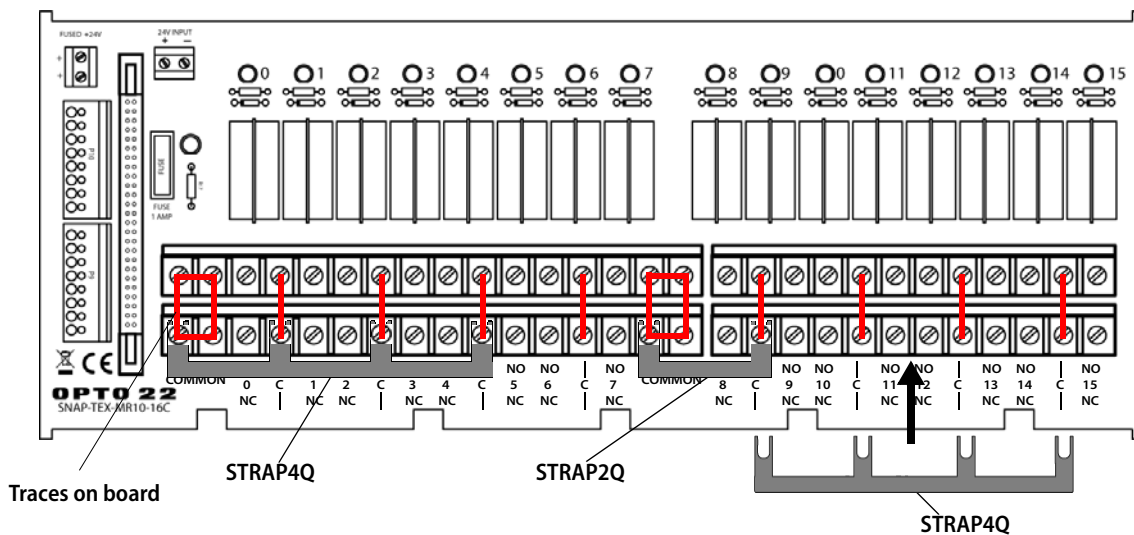

Traces on board

STRAP4Q

STRAP2Q

STRAP4Q

# SNAP TEX Cables and Breakout Boards

## SNAP-IDC-HDB and SNAP-ODC-HDB Breakout Boards

SNAP-IDC-HDB, SNAP-IDC-HDB-FM, SNAP-ODC-HDB, and SNAP-ODC-HDB-FM breakout boards provide LED indicators and easily accessible fused connectors for points on 32-channel digital input or output modules.

See Opto 22 form 1547, the *High-Density Module User's Guide*, for SNAP-IDC-HDB and SNAP-ODC-HDB breakout rack wiring and jumper settings.

### Specifications

SNAP-IDC-HDB and SNAP-IDC-HDB-FM Breakout Racks for High-Density Digital Input Modules	
Used with	SNAP-IDC-32, SNAP-IDC-32-FM, SNAP-IDC-32N, and SNAP-IDC-32DN
Connectors	40-pin header connects to 32-channel input module using SNAP-HD-BF6 header cable. 32 signal input connectors; each signal connector has a corresponding common connector. For each zone of 8 signal inputs, 1 connection for either module common or field common.
Indicators	1 LED for each signal input (32 signal LEDs total) 1 power status LED for each zone of 8 signal inputs (4 power LEDs total)
Fusing	1 A fuses; 2 fuses for each zone of 8 signal inputs (8 fuses total) Replace with Pudenz 1 A automobile mini-fuse or equivalent.
Jumpers	For each zone of 8 signal inputs, 1 jumper controls whether module common or field common is used.
Voltage	32 VDC maximum, 12-24 VDC nominal
Agency Approvals	SNAP-IDC-HDB: UL, CE, RoHS, DFARS SNAP-IDC-HDB-FM: FM, CE, RoHS, DFARS
Warranty	30 months from date of manufacture
SNAP-ODC-HDB and SNAP-ODC-HDB-FM Breakout Racks for High-Density Digital Output Modules	
Used with	SNAP-ODC-32-SRC, SNAP-ODC-32-SRC-FM, SNAP-ODC-32-SNK, and SNAP-ODC-32-SNK-FM
Connectors	40-pin header; connects to 32-channel sourcing or sinking module using SNAP-HD-BF6 header cable. 32 signal output connectors; each signal connector has a corresponding common connector. For each zone of 8 signal outputs, 1 connection for either module common or field common.
Indicators	1 LED for each signal output (32 signal LEDs total) 1 power status LED for each zone of 8 signal outputs (4 power LEDs total)
Fusing	1 A fuses; 1 fuse for each signal output (32 signal fuses total) Replace with Pudenz 1 A automobile mini-fuse or equivalent.
Jumpers	For each zone of 8 signal inputs, 1 jumper controls whether module common or field common is used.
Voltage	32 VDC maximum, 12-24 VDC nominal
Agency Approvals	SNAP-ODC-HDB: UL, CE, RoHS, DFARS SNAP-ODC-HDB-FM: FM, CE, RoHS, DFARS
Warranty	30 months from date of manufacture

# SNAP TEX Cables and Breakout Boards

## SNAP-IDC-HDB and SNAP-ODC-HDB Breakout Boards (continued)

### Dimensional Drawings

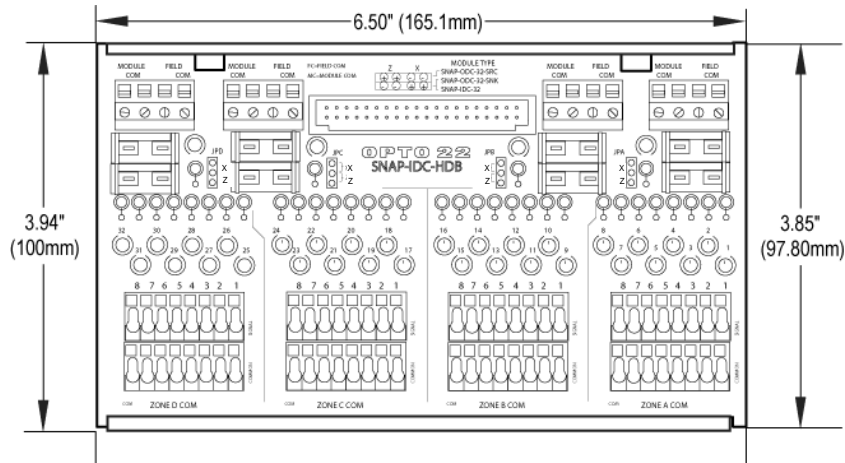

SNAP-IDC-HDB and SNAP-IDC-HDB-FM breakout racks

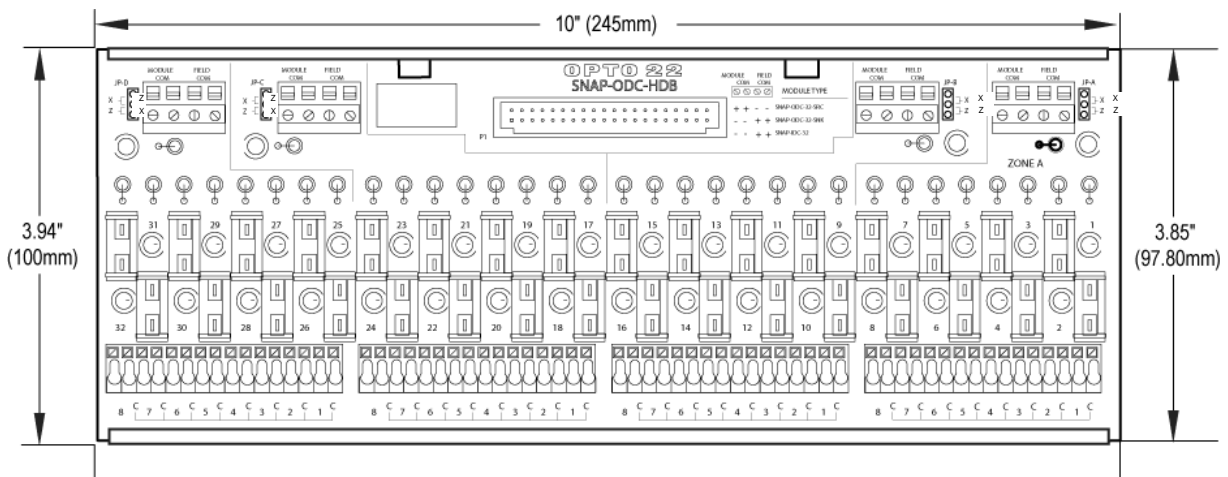

SNAP-ODC-HDB and SNAP-ODC-HDB-FM breakout racks

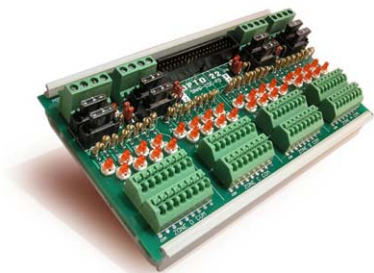

For wiring diagrams and jumper settings, see Opto 22 form 1547, the *SNAP High-Density Digital Module User's Guide*.

# SNAP TEX Cables and Breakout Boards

## SNAP-AIMA-HDB and SNAP-AIV-HDB Breakout Boards

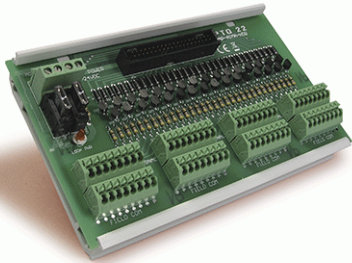

SNAP-AIMA-HDB breakout board

SNAP-AIMA-HDB, SNAP-AIMA-HDB-FM, SNAP-AIV-HDB, and SNAP-AIV-HDB-FM breakout boards are primarily designed for use with SNAP-AIMA-32, SNAP-AIMA-32-FM, SNAP-AIV-32, and SNAP-AIV-32-FM analog input modules, respectively. Each of these modules provides 32 input points. The breakout boards provide easy accessibility for wiring points to field devices. Use the SNAP-HD-BF6 cable for wiring connections between the module and the breakout board.

*Note for the SNAP-AIMA-32 or SNAP-AIMA-32-FM:* if you are using one of these modules with loop power (2-wire) devices, connect to the SNAP-AIMA-HDB or SNAP-AIMA-HDB-FM rack as shown on [page 25](#). If you are using the SNAP-AIMA-32 (or -FM) with self-powered devices (4-wire), do not use the SNAP-AIMA-HDB (or -FM) boards, which have a current limiter. Instead, wire to the SNAP-AIV-HDB or SNAP-AIV-HDB-FM as shown on [page 26](#) (negative common or [page 27](#) (positive common).

**CAUTION:** We strongly recommend that you use a breakout board with the SNAP-AIMA-32 (or -FM) module. Without the board, miswiring of any point on the module can cause severe out-of-warranty damage. The breakout board protects the module from many wiring errors.

### Working with Module Values

AIMA modules used with a SNAP-AIV-HDB board read normally. However, values on AIMA modules used with a SNAP-AIMA-HDB board are read as *negative values*. For example, a value of 10 mA on the module will be read as -10 mA. (Note: If no readings appear, try reversing field connections on the board.)

Because these readings are negative values, they can be confusing to work with. This section shows you how to easily change them to positive values or scale them to the positive

readings you need. This section applies only with the SNAP-AIMA-HDB board.

### Changing Negative to Positive Values

(SNAP-AIMA-HDB board only) To read positive values, when you configure points on the module, choose the scalable option and enter the corresponding positive values, like this:

Edit Analog Point

Name: Input\_1

Description:

Type: Input

Module: SNAP-AIMA-32: -20 .. +20 mA (Scalable)

Full Range		Clamping		Scaling	
Units:	Lower:	Upper:	Actual:	Scaled:	
mA	-20	20	mA	20	
			-20	4	
			-4		

Buttons: Clear, Default

This may seem odd, but it works. Don't be confused by the "Lower" and "Upper" labels for the values. Positive values sent to the module will be shown as the correct positive values within your PAC Control strategy.

### Scaling Values

Similarly, if you need to scale values for your application, enter the positive values you need. The module's range is 4 to 20 mA. If you want 4 to represent 0 mA and 20 to represent 130 mA, for example, enter those values as shown below:

Edit Analog Point

Name: Input\_1

Description:

Type: Input

Module: SNAP-AIMA-32: -20 .. +20 mA (Scalable)

Full Range		Clamping		Scaling	
Units:	Lower:	Upper:	Actual:	Scaled:	
mA	-20	20	mA	130	
			-20	0	
			-4		

Buttons: Clear, Default



# SNAP TEX Cables and Breakout Boards

## SNAP-AIMA-HDB Breakout Boards

### Wiring diagram: SNAP-AIMA-HDB or SNAP-AIMA-HDB-FM board to SNAP-AIMA-32 or SNAP-AIMA-32-FM module

This diagram cannot be used with self-sourcing transmitters. Use this diagram only with loop power (2-wire) negative common devices. For self-powered (4-wire) devices, use a SNAP-AIV-HDB board and wiring diagram on [page 26](#) (negative common devices) or [page 27](#) (positive common devices).

See "Working with Module Values" on [page 24](#).

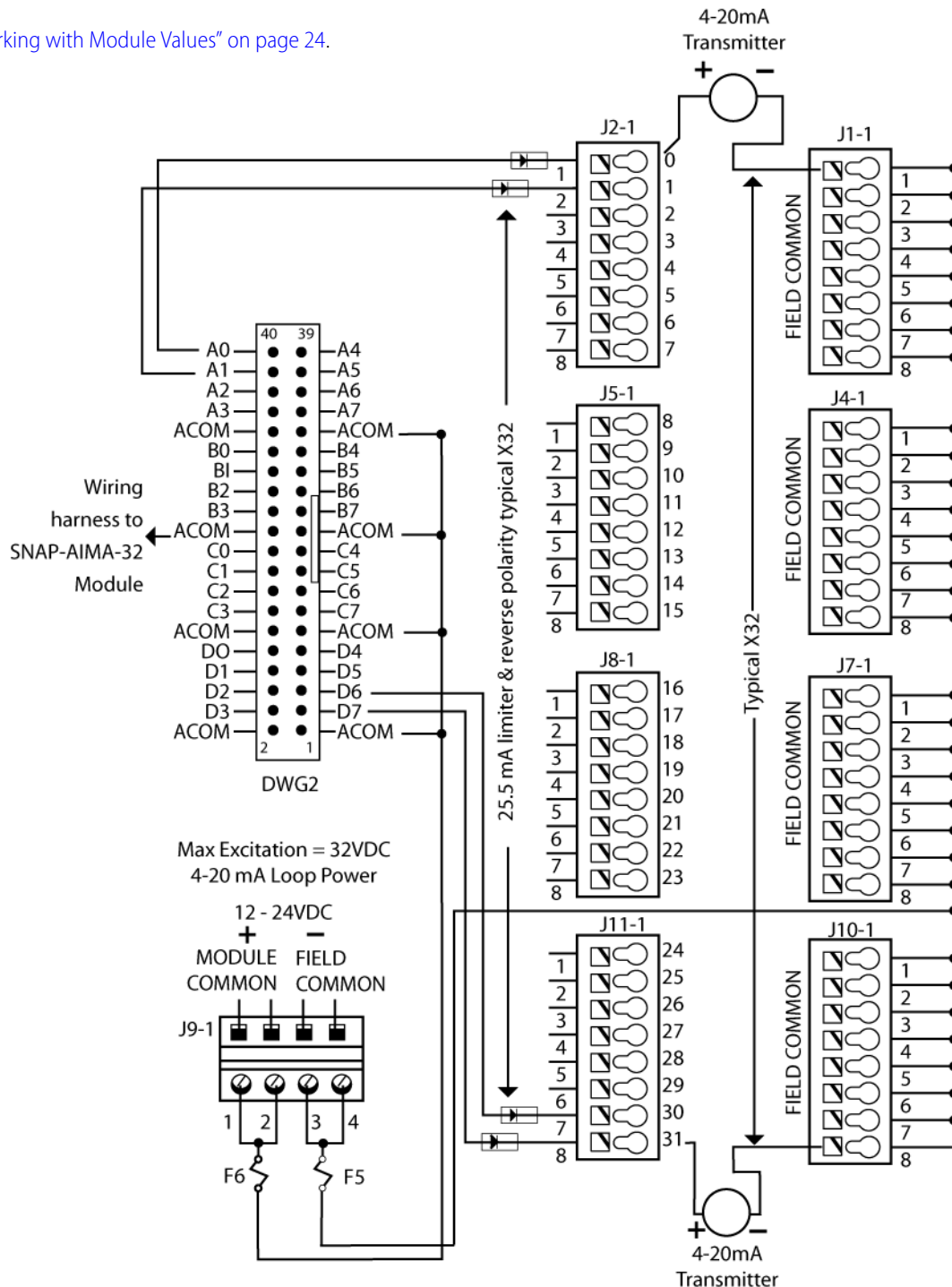

# SNAP TEX Cables and Breakout Boards

## SNAP-AIV-HDB Breakout Boards

### Wiring diagram: SNAP-AIV-HDB or SNAP-AIV-HDB-FM board to SNAP-AIV-32 or SNAP-AIV-32-FM module

NOTE: Also use this diagram to wire the SNAP-AIV-HDB breakout rack to a **SNAP-AIMA-32** or SNAP-AIMA-32-FM module, when the module connects to self-powered (4-wire) devices that share a negative common connection. (For positive common devices, use the diagram on [page 27](#).) See the module's data sheet for more information.

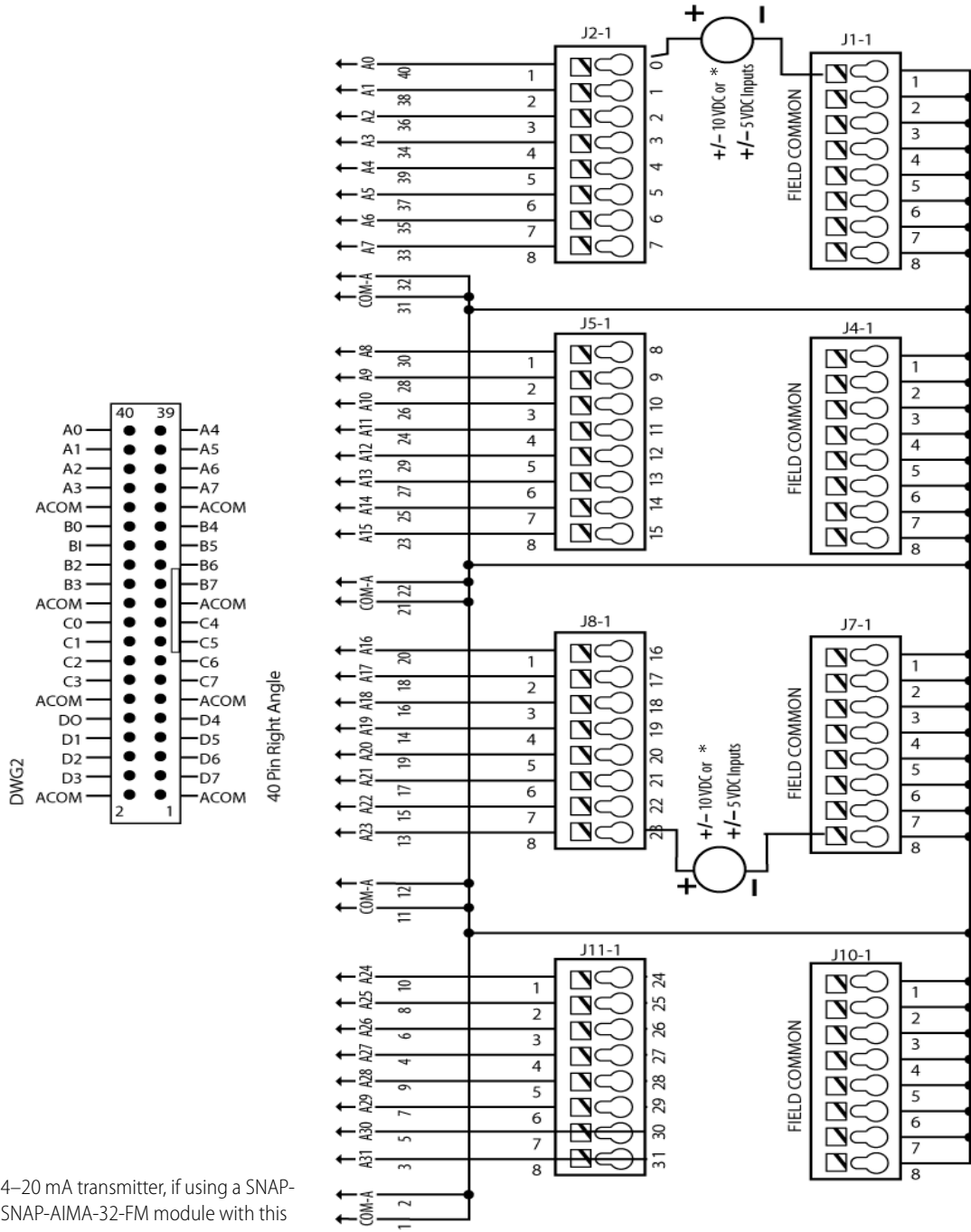

# SNAP TEX Cables and Breakout Boards

## SNAP-AIV-HDB Breakout Boards (continued)

### Wiring diagram: SNAP-AIV-HDB or SNAP-AIV-HDB-FM board to SNAP-AIMA-32 or SNAP-AIMA-32-FM module

NOTE: Use this diagram only when the module connects to self-powered (4-wire) devices that share a positive common connection. (For negative common devices, use the diagram on [page 26](#).) See the module's data sheet for more information.

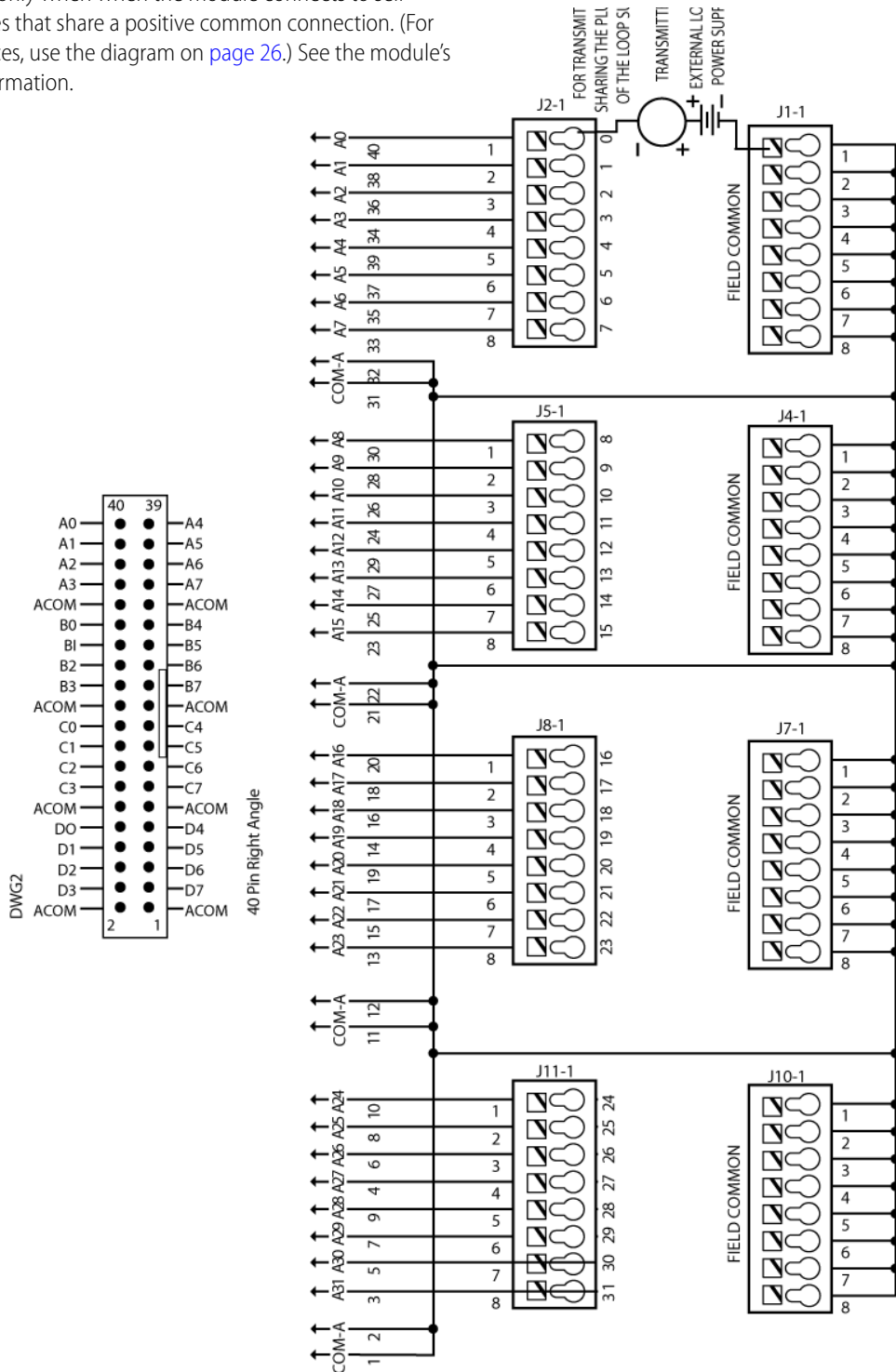

# SNAP TEX Cables and Breakout Boards

## SNAP-AIMA-HDB and SNAP-AIV-HDB Breakout Boards (continued)

**Dimensional Drawing—SNAP-AIMA-HDB and SNAP-AIMA-HDB-FM Breakout Boards**

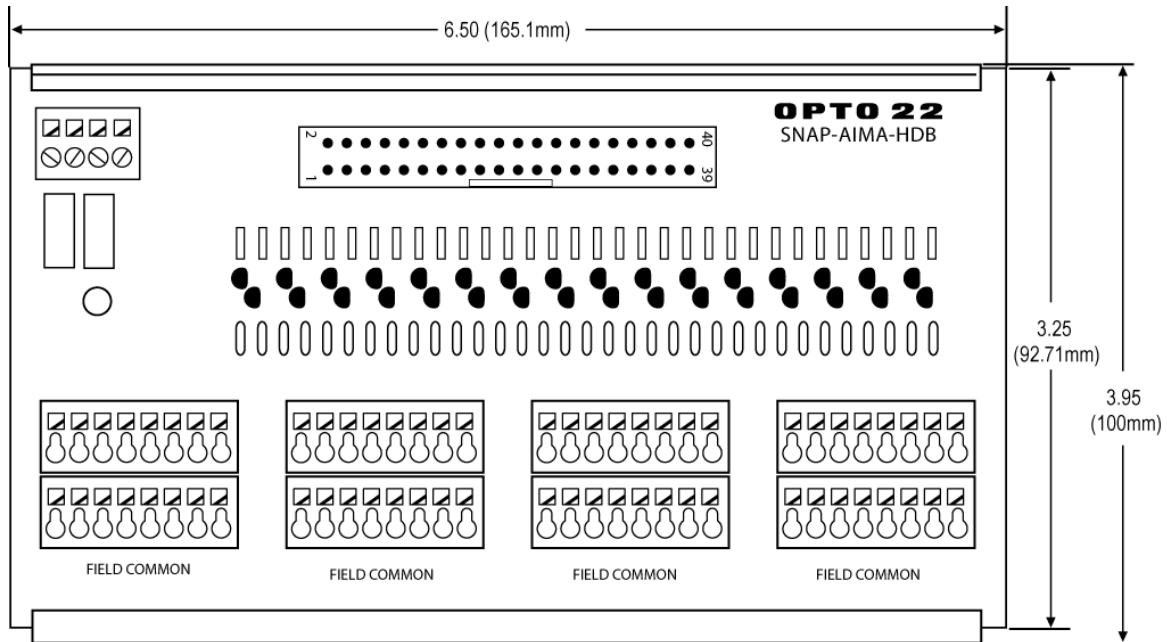

**Dimensional Drawing—SNAP-AIV-HDB and SNAP-AIV-HDB-FM Breakout Boards**

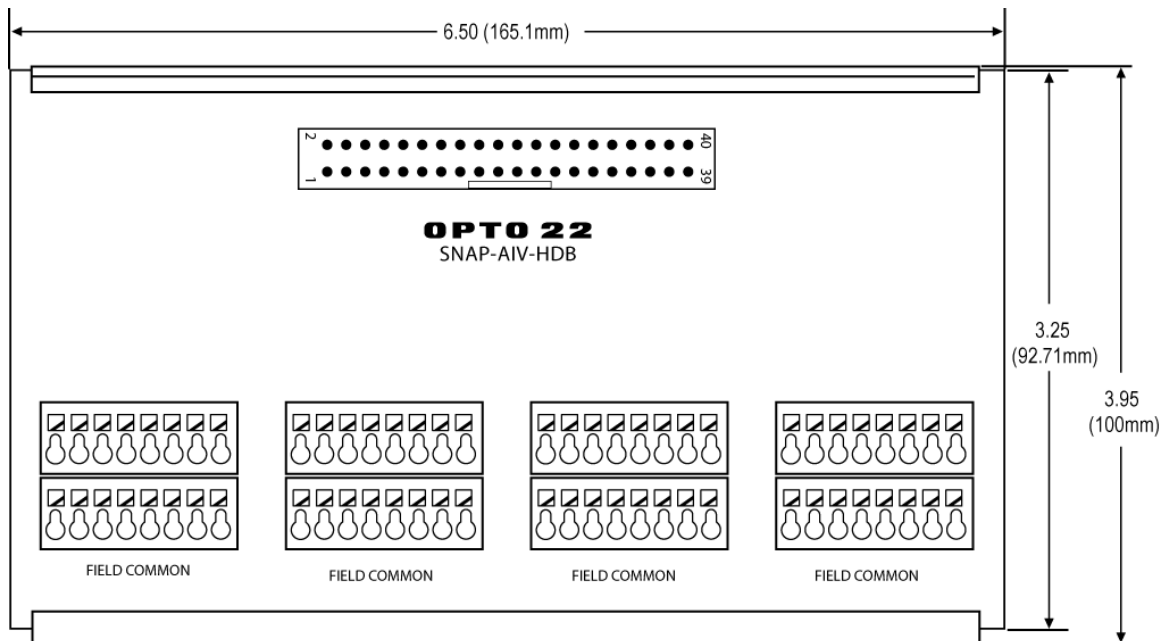

## More About Opto 22

### Products

Opto 22 develops and manufactures reliable, flexible, easy-to-use hardware and software products for industrial automation, energy management, remote monitoring, and data acquisition applications.

#### OptoEMU Energy Management System

The easy-to-use OptoEMU Sensor monitors electrical energy use in your facility and delivers detailed, real-time data you can see, analyze, and use in building and control systems. The Sensor can monitor energy data from pulsing meters, electrical panels or subpanels, and equipment. View energy data online using a software service or incorporate the data into your control system for complete energy management.

#### SNAP PAC System

Designed to simplify the typically complex process of selecting and applying an automation system, the SNAP PAC System consists of four integrated components:

- SNAP PAC controllers
- PAC Project™ Software Suite
- SNAP PAC brains
- SNAP I/O™

#### SNAP PAC Controllers

Programmable automation controllers (PACs) are multifunctional, modular controllers based on open standards.

Opto 22 has been manufacturing PACs for over two decades. The standalone SNAP PAC S-series, the rack-mounted SNAP PAC R-series, and the software-based SoftPAC™ all handle a wide range of digital, analog, and serial functions for data collection, remote monitoring, process control, and discrete and hybrid manufacturing.

SNAP PACs are based on open Ethernet and Internet Protocol (IP) standards, so you can build or extend a system easily, without the expense and limitations of proprietary networks and protocols. Wired+Wireless™ models are also available.

#### PAC Project Software Suite

Opto 22's PAC Project Software Suite provides full-featured, cost-effective control programming, HMI (human machine interface) development and runtime, OPC server, and database connectivity software for your SNAP PAC System.

Control programming includes both easy-to-learn flowcharts and optional scripting. Commands are in plain English; variables and I/O point names are fully descriptive.

PAC Project Basic offers control and HMI tools and is free for download on our website, [www.opto22.com](http://www.opto22.com). PAC Project Professional, available for separate purchase, adds one

SoftPAC, OptoOPCServer, OptoDataLink, options for controller redundancy or segmented networking, and support for legacy Opto 22 serial *mistic*™ I/O units.

#### SNAP PAC Brains

While SNAP PAC controllers provide central control and data distribution, SNAP PAC brains provide distributed intelligence for I/O processing and communications. Brains offer analog, digital, and serial functions, including thermocouple linearization; PID loop control; and optional high-speed digital counting (up to 20 kHz), quadrature counting, TPO, and pulse generation and measurement.

#### SNAP I/O

I/O provides the local connection to sensors and equipment. Opto 22 SNAP I/O offers 1 to 32 points of reliable I/O per module, depending on the type of module and your needs.

Analog, digital, and serial modules are all mixed on the same mounting rack and controlled by the same processor (SNAP PAC brain or rack-mounted controller).

### Quality

Founded in 1974, Opto 22 has established a worldwide reputation for high-quality products. All are made in the U.S.A. at our manufacturing facility in Temecula, California. Because we test each product twice before it leaves our factory, rather than only testing a sample of each batch, we can guarantee most solid-state relays and optically isolated I/O modules for life.

### Free Product Support

Opto 22's California-based Product Support Group offers free, comprehensive technical support for Opto 22 products. Our staff of support engineers represents decades of training and experience. Support is available in English and Spanish by phone or email, Monday–Friday, 7 a.m. to 5 p.m. PST.

Additional support is always available on our website: how-to videos, OptoKnowledgeBase, self-training guide, troubleshooting and user's guides, and OptoForums.

In addition, hands-on training is available for free at our Temecula, California headquarters, and you can [register online](#).

### Purchasing Opto 22 Products

Opto 22 products are sold directly and through a worldwide network of distributors, partners, and system integrators. For more information, contact Opto 22 headquarters at 800-321-6786 or 951-695-3000, or visit our website at [www.opto22.com](http://www.opto22.com).

[www.opto22.com](http://www.opto22.com)

