

**CONTINUOUS HINGE WITH CLAMPS, EMC, TYPE 12**

**APPLICATION**

This enclosure is used in indoor applications to contain stray electromagnetic interference (EMI) signals produced by internal components and to shield those components from external EMI/RFI interference.

**SPECIFICATIONS**

- 16 or 14 gauge steel
- Seams continuously welded and ground smooth
- Continuous hinge
- Bonding provision on door
- Combination woven steel mesh and oil-resistant gasket
- Stainless steel cover clamps and screws
- Weldnuts provided for mounting optional panels and terminal kits in size 6.00 x 4.00 in. (152 x 102mm) and larger
- Shielding effectiveness greater than 80 dB at 1 GHz

**FINISH**

Plated finish provides conductive surfaces for gasket contact areas and conduit entries.

**ACCESSORIES**

See also *Accessories*.

Industrial Corrosion Inhibitors

Fast-Operating Clamp-Cover Junction Box Clamp

Panels for Junction Boxes

Junction Box and Wall-Mount Enclosure Swing Out Panel Kit

Terminal Block Kit Assembly for Junction Boxes Overview

**BULLETIN: A53**

**INDUSTRY STANDARDS**

UL 50, 50E Listed; Type 12, 13; File No. E27567  
 cUL Listed per CSA C22.2 No. 94; Type 12, 13; File No. E27567  
 UL 508A Listed; Type 12, 13; File No. E61997  
 cUL Listed per CSA C22.2 No. 94; Type 12,13; File No. E61997

NEMA/EEMAC Type 12, 13  
 CSA, File No. 42184: Type 12, 13  
 IEC 60529, IP54

## Standard Product

Catalog Number	AxBxC in./mm	Gauge	UL Listed	Panel	Conductive Panel	Panel Size D x E in./mm	Mounting G x H in./mm	Overall L x W in./mm	F in./mm	J in./mm	K in./mm	T in./mm	V in./mm	Y in./mm
A604CHEMC	6.00 x 4.00 x 3.00	16	508A	A6P4	A6P4G	4.88 x 2.88	6.75 x 2.00	7.50 x 4.81	2.53	2.62	0.54	3.00	0.31	0.56
	152 x 102 x 76					124 x 73	171 x 51	191 x 122	64	66	14	76	8	14
A806CHEMC	8.00 x 6.00 x 3.50	14	50, 50E	A8P6	A8P6G	6.75 x 4.88	8.75 x 4.00	9.51 x 6.81	3.03	3.12	0.56	5.00	0.25	0.62
	203 x 152 x 89					171 x 124	222 x 102	241 x 173	77	79	14	127	6	16
A606CHEMC	6.00 x 6.00 x 4.00	16	50, 50E	A6P6	A6P6G	4.88 x 4.88	6.75 x 4.00	7.50 x 6.81	3.53	3.62	0.54	5.00	0.31	0.56
	152 x 152 x 102					124 x 124	171 x 102	191 x 173	90	92	14	127	8	14
A1008CHEMC	10.00 x 8.00 x 4.00	14	50, 50E	A10P8	A10P8G	8.75 x 6.88	10.75 x 6.00	11.50 x 8.81	3.53	3.62	0.56	7.00	0.25	0.62
	254 x 203 x 102					222 x 175	273 x 152	292 x 224	90	92	14	178	6	16
A1210CHEMC	12.00 x 10.00 x 5.00	14	50, 50E	A12P10	A12P10G	10.75 x 8.88	12.75 x 8.00	13.50 x 10.81	4.53	4.62	0.56	9.00	0.25	0.62
	305 x 254 x 127					273 x 226	324 x 203	343 x 275	115	117	14	229	6	16
A1412CHEMC	14.00 x 12.00 x 6.00	14	50, 50E	A14P12	A14P12G	12.75 x 10.88	14.75 x 10.00	15.50 x 12.81	5.53	5.62	0.56	11.00	0.25	0.62
	356 x 305 x 152					324 x 276	375 x 254	394 x 325	140	143	14	279	6	16
A1614CHEMC	16.00 x 14.00 x 6.00	14	50, 50E	A16P14	A16P14G	14.75 x 12.88	16.75 x 12.00	17.50 x 14.81	5.53	5.62	0.56	13.00	0.25	0.62
	406 x 356 x 152					375 x 327	425 x 305	445 x 376	140	143	14	330	6	16

Purchase panels separately.

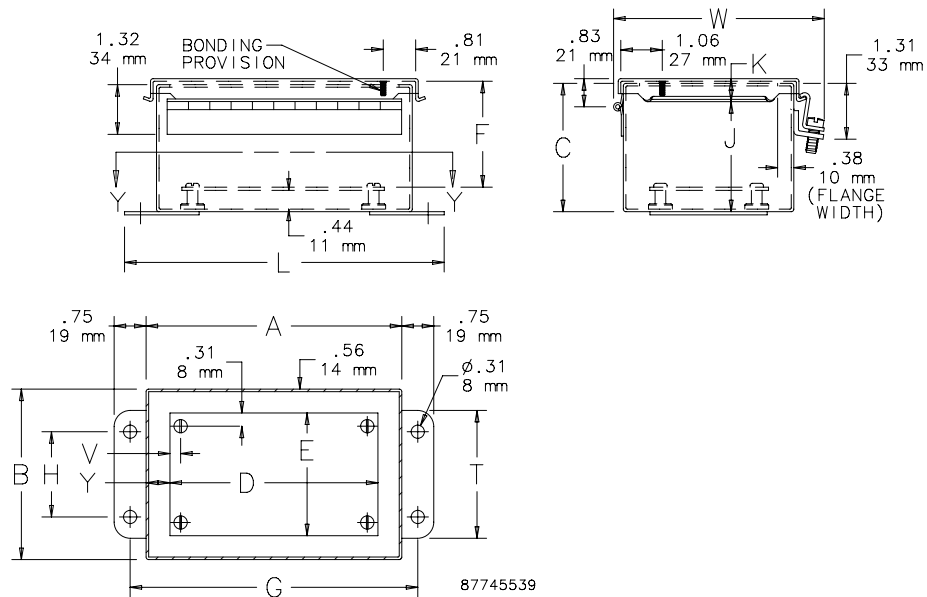

SECTION Y-Y

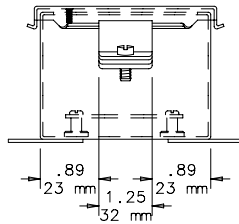

Clamp End of Box,  
One Clamp Used

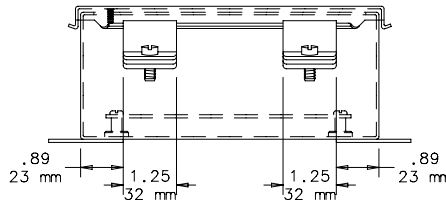

Clamp End of Box,  
Two Clamps Used

**Steel JIC Shielding Effectiveness**  
Standard Mild Steel JIC Cabinet Compared to EMC Mild Steel JIC Cabinet

